



UL 1310

STANDARD FOR SAFETY
Class 2 Power Units

***UL COPYRIGHTED MATERIAL –
NOT AUTHORIZED FOR FURTHER REPRODUCTION OR
DISTRIBUTION WITHOUT PERMISSION FROM UL***

UL Standard for Safety for Class 2 Power Units, UL 1310

Sixth Edition, Dated August 26, 2011

Summary of Topics

This revision of ANSI/UL 1310 includes the following changes in requirements:

Addition of requirements to address a flush device cover plate with integral power supply with Class 2 output connectors with or without a night light

Text that has been changed in any manner or impacted by UL's electronic publishing system is marked with a vertical line in the margin. Changes in requirements are marked with a vertical line in the margin and are followed by an effective date note indicating the date of publication or the date on which the changed requirement becomes effective.

The new requirements are substantially in accordance with Proposal(s) on this subject dated October 3, 2014.

All rights reserved. No part of this publication may be reproduced, stored in a retrieval system, or transmitted in any form by any means, electronic, mechanical photocopying, recording, or otherwise without prior permission of UL.

UL provides this Standard "as is" without warranty of any kind, either expressed or implied, including but not limited to, the implied warranties of merchantability or fitness for any purpose.

In no event will UL be liable for any special, incidental, consequential, indirect or similar damages, including loss of profits, lost savings, loss of data, or any other damages arising out of the use of or the inability to use this Standard, even if UL or an authorized UL representative has been advised of the possibility of such damage. In no event shall UL's liability for any damage ever exceed the price paid for this Standard, regardless of the form of the claim.

Users of the electronic versions of UL's Standards for Safety agree to defend, indemnify, and hold UL harmless from and against any loss, expense, liability, damage, claim, or judgment (including reasonable attorney's fees) resulting from any error or deviation introduced while purchaser is storing an electronic Standard on the purchaser's computer system.

The requirements in this Standard are now in effect, except for those paragraphs, sections, tables, figures, and/or other elements of the Standard having future effective dates as indicated in the note following the affected item. The prior text for requirements that have been revised and that have a future effective date are located after the Standard, and are preceded by a "SUPERSEDED REQUIREMENTS" notice.

***UL COPYRIGHTED MATERIAL –
NOT AUTHORIZED FOR FURTHER REPRODUCTION OR
DISTRIBUTION WITHOUT PERMISSION FROM UL***

No Text on This Page

***UL COPYRIGHTED MATERIAL –
NOT AUTHORIZED FOR FURTHER REPRODUCTION OR
DISTRIBUTION WITHOUT PERMISSION FROM UL***

AUGUST 26, 2011
(Title Page Reprinted: December 12, 2014)



ANSI/UL 1310-2014

1

UL 1310

Standard for Class 2 Power Units

The first and second editions were titled Standard for Direct Plug-In Transformer Units.

First Edition – May, 1981
Second Edition – September, 1986
Third Edition – August, 1992
Fourth Edition – July, 1994
Fifth Edition – May, 2005

Sixth Edition

August 26, 2011

This ANSI/UL Standard for Safety consists of the Sixth Edition including revisions through December 12, 2014.

The most recent designation of ANSI/UL 1310 as an American National Standard (ANSI) occurred on December 10, 2014. ANSI approval for a standard does not include the Cover Page, Transmittal Pages, Title Page, or effective date information.

Comments or proposals for revisions on any part of the Standard may be submitted to UL at any time. Proposals should be submitted via a Proposal Request in UL's On-Line Collaborative Standards Development System (CSDS) at <http://csds.ul.com>.

UL's Standards for Safety are copyrighted by UL. Neither a printed nor electronic copy of a Standard should be altered in any way. All of UL's Standards and all copyrights, ownerships, and rights regarding those Standards shall remain the sole and exclusive property of UL.

COPYRIGHT © 2014 UNDERWRITERS LABORATORIES INC.

***UL COPYRIGHTED MATERIAL –
NOT AUTHORIZED FOR FURTHER REPRODUCTION OR
DISTRIBUTION WITHOUT PERMISSION FROM UL***

No Text on This Page

***UL COPYRIGHTED MATERIAL –
NOT AUTHORIZED FOR FURTHER REPRODUCTION OR
DISTRIBUTION WITHOUT PERMISSION FROM UL***

CONTENTS

INTRODUCTION

1 Scope	7
2 Components	8
3 Units of Measurement	9
4 Undated References	9
5 Glossary	9
6 Terminology	11

CONSTRUCTION

7 Mechanical Assembly	11
8 Enclosure	18
9 Protection Against Corrosion	19
10 Switches	19
11 Protective Devices	20
12 Components	21
13 Coil Insulation	22
13.1 General	22
13.2 Insulation for transformers	22
14 Input Connections	25
14.1 Direct plug-in units	25
14.2 Cord-connected units	26
14.3 DC input units	27
15 Output Connections	27
15.1 General	27
15.2 Output wiring	28
15.3 Output terminals	28
15.4 Output connectors	29
15.5 Bushings	30
16 Accessibility of Live Parts	30
16.1 General	30
16.2 Live parts other than exposed wiring terminals	33
16.3 Exposed wiring terminals	35
17 Live Parts	35
18 Strain Relief	36
19 Internal Wiring	36
20 Separation of Circuits	37
21 Insulating Materials	37
22 Printed-Wiring Boards	37
23 Grounding	38
23.1 General	38
23.2 Bonding conductor	39
24 Spacings	39

**UL COPYRIGHTED MATERIAL –
NOT AUTHORIZED FOR FURTHER REPRODUCTION OR
DISTRIBUTION WITHOUT PERMISSION FROM UL**

PERFORMANCE

25	General	42
26	Leakage Current Test	45
27	Leakage Current Test and Dielectric Voltage Withstand Test After Humidity Exposure	47
28	Maximum Output Voltage Test	48
29	Maximum Input Test	48
30	Output Current and Power Test	48
	30.1 General	48
	30.2 Inherently limited	49
	30.3 Not inherently limited	50
31	Calibration of Overcurrent Protection Devices Test	51
32	Full-Load Output Current Test	51
33	Normal Temperature Test	52
34	Dielectric Voltage Withstand Test	56
	34.1 General	56
	34.2 Induced potential	57
35	Endurance Test on Overcurrent- and Overtemperature-Protective Devices	57
36	Overload and Endurance Tests on Switches and Controls	58
37	Overload Test on Secondary Switches	58
38	Operation Test	59
39	Abnormal Tests	59
	39.1 General	59
	39.2 Output loading	60
	39.3 Output loading – alternate method	61
	39.4 Transformer burnout	62
	39.5 Reverse polarity	62
	39.6 Switch position	63
	39.7 Component breakdown	63
	39.8 Printed-wiring board abnormal operation test	63
	39.9 Backfeed protection	64
40	Tests on Insulating Materials	65
41	Strain Relief Test	66
42	Push-Back Relief Test	66
43	Direct Plug-In Blade Secureness Test	67
44	Direct Plug-In Security of Input Contacts Test	67
	44.1 General	67
	44.2 Removable, folding, and retractable blade units	67
45	Security of Output Connectors Test	68
46	Abuse Tests	69
	46.1 General	69
	46.2 Impact on direct plug-in units	69
	46.3 Impact on cord connected units	71
	46.4 Rod pressure on direct plug-in units	71
	46.5 Resistance to crushing on direct plug-in units	71
47	Bonding Conductor Test	72

MANUFACTURING AND PRODUCTION TESTS

48	Dielectric Voltage Withstand Test	72
49	Grounding Continuity Test	74

**UL COPYRIGHTED MATERIAL –
NOT AUTHORIZED FOR FURTHER REPRODUCTION OR
DISTRIBUTION WITHOUT PERMISSION FROM UL**

RATING

50 General	74
------------------	----

MARKING

51 General	75
52 Cautionary and Warning Markings	76
53 Application of Labeling	78

INSTRUCTIONS

54 Instruction Manual	78
-----------------------------	----

OUTDOOR USE

55 General	79
56 Enclosures	79
57 Protection Against Corrosion	80
58 Gaskets	83
59 Supply Connections	83
60 Output Connections and Wiring	84
61 Spacings	84
62 Accessibility of Live Parts	85
63 Ground-Fault Circuit-Interrupters	85
64 Performance	86
64.1 General	86
64.2 Abuse tests	86
64.3 Rain test	86
64.4 Standing water immersion test	90
65 Markings	90
66 Instructions	91

PERMANENTLY-CONNECTED UNITS FOR CONNECTION TO A WIRING SYSTEM

67 General	92
68 Construction	93
69 Wiring Terminals and Leads	94
69A Strain Relief Test	94A
70 Markings	95
71 Installation Instructions	96

PERMANENTLY-CONNECTED UNITS FOR INSTALLATION IN AN OUTLET BOX

71A General	96A
71B Construction	96A
71C Polymeric Enclosures	96B
71D Spacings	96B
71E Performance	96B
71E.1 General	96B
71E.2 Assembly test	96C
71F Installation Instructions	96D
71G User Instructions	96D

**UL COPYRIGHTED MATERIAL –
NOT AUTHORIZED FOR FURTHER REPRODUCTION OR
DISTRIBUTION WITHOUT PERMISSION FROM UL**

71H Markings96E
--------------------	------

POWER UNITS FOR INSTALLATION IN AIR-HANDLING SPACES

72 General96E
73 Marking97

POWER UNITS SUPPLIED FROM INFORMATION TECHNOLOGY EQUIPMENT DATA PORTS

74 General97
75 Glossary97
76 Supply Connections98
77 Enclosure98
78 Performance98
78.1 General98
78.2 Abnormal temperature test99
78.3 Strain relief test99
79 Markings99
80 Instructions100

FLUSH DEVICE COVER PLATES WITH INTEGRAL POWER SUPPLY

81 General100
82 Construction100
83 Polymeric Enclosures101
84 Spacings101
85 Configurations102
86 Class 2 Output Power Supply Testing102
87 Assembly Test103
88 Installation Instructions104
89 Markings104

APPENDIX A

Standards for Components	A1
--------------------------------	----

INTRODUCTION

1 Scope

1.1 These requirements cover indoor and outdoor use Class 2 power supplies and battery chargers. These units utilize an isolating transformer and may incorporate components to provide an alternating- or direct-current output. Each output provides Class 2 power levels in accordance with the National Electrical Code, ANSI/NFPA 70. Maximum output voltage does not exceed 42.4 V peak for alternating current, 60 V for continuous direct current. These products are intended primarily to provide power to low voltage, electrically operated devices. These requirements apply to:

- a) Portable and semipermanent mounted direct plug-in units provided with 15 A blade configurations for use on nominal 120 or 240 V alternating current branch circuits with a maximum potential of 150 V to ground;
- b) Cord- and plug-connected units provided with a 15 or 20 A attachment plug configuration for use on nominal 120 or 240 V alternating current branch circuits with a maximum potential of 150 V to ground; and
- c) Units permanently connected to the input supply for use on nominal 600 V or less alternating or direct current branch circuit.

Direct plug-in and cord-connected units may also be provided with an integral cigarette lighter connector assembly, or a direct current input jack for being powered from a vehicle battery adapter or from a data port associated with information technology equipment. These units utilize an isolating transformer and may incorporate components to provide an alternating- or direct-current output. Each output provides Class 2 power levels in accordance with the National Electrical Code, ANSI/NFPA 70. Maximum output voltage does not exceed 42.4 V peak for alternating current, 60 V for continuous direct current. These products are intended primarily to provide power to low voltage, electrically operated devices.

1.2 These requirements cover direct plug-in and cord-connected products whose input power does not exceed 660 W under any possible condition of output loading.

1.3 These requirements do not cover the effect that a power unit may have on the equipment or system to which it is connected.

1.4 A product marked for a specific end-use involving additional considerations may be subject to additional requirements found in the applicable end-product standard. See 51.4. Examples include considerations related to:

- a) Mechanical risks such as those presented by tools;
- b) Build up of static charges such as those of radio equipment with external antennae connections;
- c) Special shock limits such as those for medical equipment; and
- d) Fire risks such as those posed by decorative lighting products.

**UL COPYRIGHTED MATERIAL –
NOT AUTHORIZED FOR FURTHER REPRODUCTION OR
DISTRIBUTION WITHOUT PERMISSION FROM UL**

1.5 These requirements do not cover products intended to charge batteries for starter motors used to start engines. Products of this type are covered by the Standard for Battery Chargers for Charging Engine-Starter Batteries, UL 1236.

1.6 These requirements cover Class 2 products, as defined in this standard, intended for use with toys. Products of this type shall also comply with the Standard for Toy Transformers, UL 697.

1.7 These requirements do not cover products with outputs other than Class 2, nor battery chargers intended to charge batteries employed in wheel chairs or similar types of mobility aids. Products of this type are covered by the Standard for Power Units Other Than Class 2, UL 1012.

1.8 Products without a rectifier may be covered by the Standard for Low Voltage Transformers – Part 1: General Requirements, UL 5085-1, and the Standard for Low Voltage Transformers – Part 3: Class 2 and Class 3 Transformers, UL 5085-3.

1.9 These requirements do not cover products powered solely by a dc source. Products of this type are covered by the Standard for Power Converters/Inverters and Power Converter/Inverter Systems for Land Vehicles and Marine Craft, UL 458, or by other requirements appropriate for the intended application.

1.10 These requirements do not cover products intended for supplying low voltage landscape lighting. Products of this type are covered by the Standard for Low Voltage Landscape Lighting Systems, UL 1838.

2 Components

2.1 Except as indicated in 2.2, a component of a product covered by this standard shall comply with the requirements for that component. See Appendix A for a list of standards covering components used in the products covered by this standard.

2.2 A component is not required to comply with a specific requirement that:

- a) Involves a feature or characteristic not required in the application of the component in the product covered by this standard, or
- b) Is superseded by a requirement in this standard.

2.3 A component shall be used in accordance with its rating established for the intended conditions of use.

2.4 Specific components are incomplete in construction features or restricted in performance capabilities. Such components are intended for use only under limited conditions, such as certain temperatures not exceeding specified limits, and shall be used only under those specific conditions.

3 Units of Measurement

3.1 Values stated without parentheses are the requirement. Values in parentheses are explanatory or approximate information.

3.2 Unless otherwise stated, values of current and voltage are rms.

4 Undated References

4.1 Any undated reference to a code or standard appearing in the requirements of this standard shall be interpreted as referring to the latest edition of that code or standard.

5 Glossary

5.1 For the purpose of this standard, the following definitions shall apply:

5.2 BONDING CONDUCTOR – A conductor by which dead metal parts are bonded (connected) to the grounding means.

5.3 CLASS 2 – A source having limited voltage and energy capacity. Requirements for voltage and energy capacity limitations are as indicated in this standard. See the Maximum Output Voltage Test, Section 28, and the Output Current and Power Test, Section 30.

5.4 CONDUCTIVELY CONNECTED – A part is conductively connected to another part if the current between the parts exceeds the limit for leakage current specified in Leakage Current Test, Section 26.

5.5 CONSECUTIVE BATTERY CHARGER – A battery charger whose charging cycle is completed in four hours or less.

5.6 DIRECT CURRENT (DC) – A voltage or current waveform where the instantaneous value does not vary.

5.7 ENCLOSURE – Any surface or surrounding structure that prevents access to a real or potential risk of electric shock or injury to persons.

5.8 ENERGY LIMITING CIRCUIT/ENERGY LIMITING IMPEDANCE – A circuit or component depended on to limit an output to Class 2 levels or to limit energy to an accessible part. Reliability of circuit components shall be determined unless the unit is tested as specified in 39.7.1.

5.9 INDOOR USE – Use in an indoor location or where wet contact is not likely to occur.

5.10 INJURY TO PERSONS – The words "injury to persons" are in reference to physical harm to persons other than the physiological effects of electric shock.

5.11 MULTIPLE VOLTAGE RATED POWER UNIT – A power unit with a rated voltage range (such as 100 – 240 volts) or a power unit with more than one discrete voltage rating (such as 120/240 volts).

5.12 POWER UNIT INTENDED FOR USE BY TRAVELERS – A multiple voltage rated direct plug-in power unit with a 125 V 15 A (parallel) input blade configuration, or a multiple voltage rated cord-connected power unit with a non-detachable power supply cord terminating in a 125 V 15 A (parallel) blade plug.

5.13 RISK OF ELECTRIC SHOCK – A risk of electric shock is considered to exist if:

UL COPYRIGHTED MATERIAL –
NOT AUTHORIZED FOR FURTHER REPRODUCTION OR
DISTRIBUTION WITHOUT PERMISSION FROM UL

- a) The voltage between parts exceeds the value specified in 16.2.2, and
- b) The current between the parts measured in the Leakage Current Test, Section 26, exceeds 0.5 mA.

5.14 TAB, INTEGRAL (including a mounting tab) – A molded on or otherwise mechanically secured tab provided as part of the enclosure. An integral tab is usually not provided as part of the required enclosure, but may be provided for compliance with certain requirements of this standard.

5.15 UNIT – For the purposes of this standard, a unit is either a direct plug-in unit, a cord connected unit, or a unit permanently connected to the input supply.

5.16 UNIT, CORD-CONNECTED – A power unit which employs a cord and plug assembly for connection to the branch circuit.

5.17 UNIT, DIRECT PLUG-IN – A power unit which employs a blade assembly on the enclosure for connection to the branch circuit.

5.18 UNIT, LINEAR DESIGN – A unit employing a branch circuit frequency transformer design where operation is not dependent on circuitry.

5.19 UNIT, PORTABLE – A unit other than a stationary unit or semipermanent mounted unit.

5.20 UNIT, SEMIPERMANENT MOUNTED – A direct plug-in unit provided with a mounting tab. For the purpose of this standard, semipermanent mounted units shall also comply with the requirements for portable units unless otherwise specified.

5.21 UNIT, STATIONARY – A cord- and plug-connected unit that is:

- a) Intended to be fastened in place;
- b) Intended to be located in a dedicated space; or
- c) Not easily moved.

5.22 UNIT, SWITCH MODE DESIGN – A unit employing a high frequency transformer design where transformer operation is dependent on an inverter circuit.

5.23 WORKING VOLTAGE – The highest voltage to which the insulation under consideration is, or is able to be, subjected when the equipment is operating at its rated voltage under conditions of normal use.

6 Terminology

6.1 The term "power unit" as used in these requirements refers to all power supplies, battery chargers, and transformers covered by these requirements.

CONSTRUCTION

7 Mechanical Assembly

7.1 A unit shall be formed and assembled so that it has the strength and rigidity necessary to resist the abuses to which it is likely to be subjected, without producing or increasing a risk of fire, electric shock, or injury to persons due to total or partial collapse with resulting reduction of spacings, loosening or displacement of parts, or other serious defects. See also 46.1.1.

7.2 A unit shall have all parts reliably secured in place.

7.3 An enclosure, an opening, a frame, a guard, a knob, a handle, or the like shall not be sufficiently sharp to cause a risk of injury in normal maintenance or use.

7.4 A unit shall be constructed so that it is not necessary to open or remove the enclosure when the unit is used as intended.

7.5 Each lampholder, switch, and similar component shall be mounted securely and shall be prevented from turning by more than friction between surfaces. For example, the use of a lock washer is acceptable to prevent the turning of a device having a single hole mounting means.

Exception No. 1: A lampholder of a type in which the lamp cannot be replaced (such as a neon pilot or indicator light in which the lamp is sealed in by a nonremovable jewel) need not be prevented from turning if rotation cannot reduce spacings below the minimum acceptable values or produce stress on an electrical connection.

Exception No. 2: A switch or other similar component need not comply with this requirement if the turning of such a component and servicing of the part introduces no additional risk of fire or electric shock, such as reduced spacings below minimum acceptable values or stress on an electrical connection.

7.6 A replaceable lamp in a unit shall be wired in the secondary circuit, and shall be replaceable without opening the enclosure. There shall be no primary live part accessible to contact during lamp replacement.

7.7 A nonreplaceable pilot lamp, such as an indicating-type overload- or short-circuit protector, a neon light, or an indicator light, is one in which the lamp is sealed-in, such as by a nonremovable jewel.

7.8 A switch in the primary circuit or an overcurrent-protective device shall be located within the unit enclosure in such a manner as not to be accessible or exposed to tampering nor subject to damage during normal use. This requirement does not apply to the actuating means of a switch, except as noted in 7.10.

7.9 If the exterior part of the switch or control forms part of a unit enclosure, the part shall be subjected to the Abuse Tests, Section 46.

7.10 The requirements in 7.8 also apply to the actuating means – toggle, handle, or the like – if the dislodging of such part exposes live parts or film-coated magnet wire that can be contacted as specified in Accessibility of Live Parts, Section 16.

7.11 The maximum acceptable moment, center of gravity, dimensions, and weight of a direct plug-in unit shall comply with the following requirements (See 7.12):

- a) The quotient of WY/Z shall not exceed 48 ounces (1361 g);
- b) The quotient of WY/S shall not exceed 48 ounces (1361 g);
- c) The product of WX shall not exceed 80 ounce-inches (0.56 N·m) for a unit not intended for use by travelers, and 36 ounce-inches (0.25 N·m) for a unit intended for use by travelers (see 14.1.4); and
- d) The weight of a unit shall not exceed 28 ounces (794 g).

Where the definitions for the symbols are as follows:

W is the weight of the unit in ounces (g).

Y is the distance illustrated in Figure 7.1 in inches (mm).

Z is the lesser of the two distances, Z_1 or Z_2 , as illustrated in Figure 7.1 in inches (mm).

S is the lesser of the two distances, S_1 or S_2 , as illustrated in Figure 7.1 in inches (mm).

X is the greater of the two distances, X_1 or X_2 , as illustrated in Figure 7.1 in inches (mm).

Figure 7.1
Dimensions of a direct plug-in unit

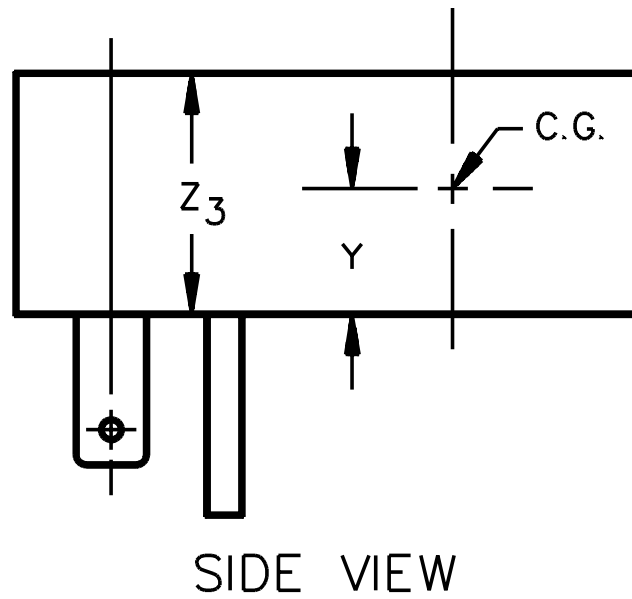
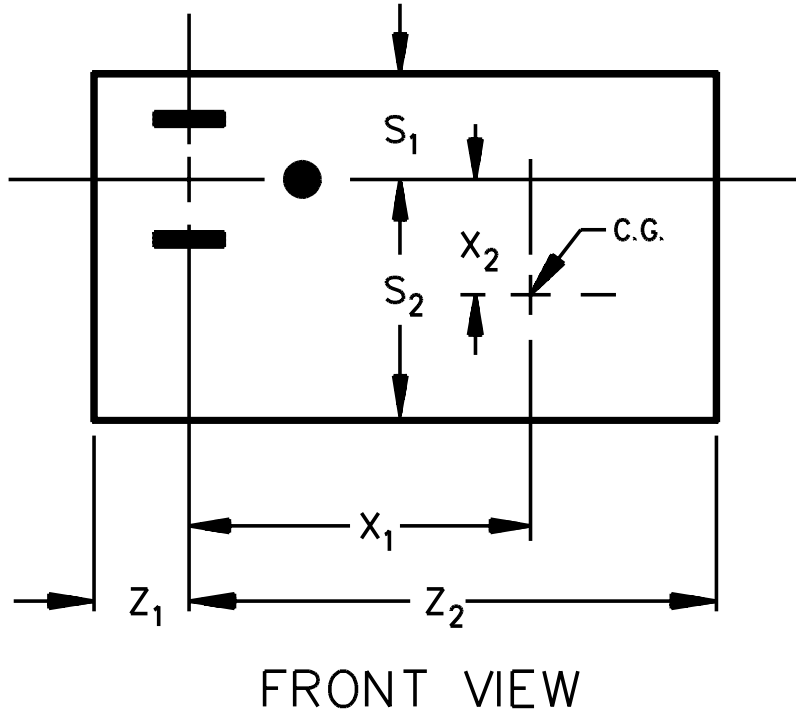

C.G. = Center of Gravity

CP100

*UL COPYRIGHTED MATERIAL –
NOT AUTHORIZED FOR FURTHER REPRODUCTION OR
DISTRIBUTION WITHOUT PERMISSION FROM UL*

7.12 The moment and weight specified in 7.11 are to be determined as follows:

- a) For units with an output cord, the cord is to be cut off at the enclosure, or at the strain-relief means if the strain-relief means is outside the enclosure.
- b) For units with directly mounted accessories, the values are to be measured with the accessories in place.
- c) An integral tab is not to be included in measurements of the linear dimensions for the purpose of determining moments unless:
 - 1) The tab and enclosure withstand the impact described in 46.2.1 with one impact on the tab itself, without deformation; and
 - 2) For a polymeric enclosed unit having an integral tab, the tab and enclosure do not distort at temperatures to which the material may be subjected under conditions of normal and abnormal use as determined by the mold stress relief distortion test in the Standard for Polymeric Materials – Use in Electrical Equipment Evaluations, UL 746C.

7.13 When inserted in a duplex receptacle, no part of a direct plug-in unit, including an integral tab or output wiring, shall interfere with full insertion of an attachment plug into the adjacent receptacle. See Figure 7.2 and Figure 7.3.

Exception: This requirement does not apply to a unit that renders the adjacent receptacle completely unusable in any one mounting position.

Figure 7.2
125V, 15A Duplex receptacle

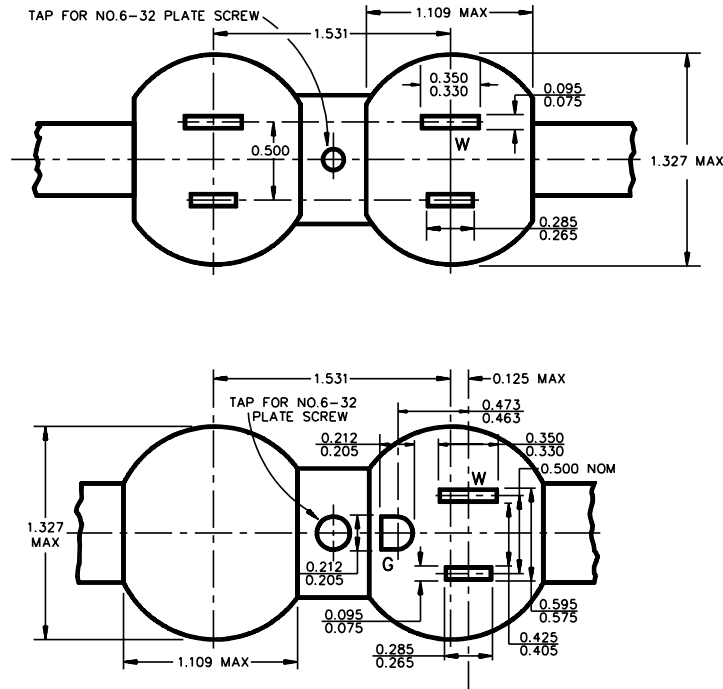

S2863A

Figure 7.3
250V, 15A Duplex receptacle

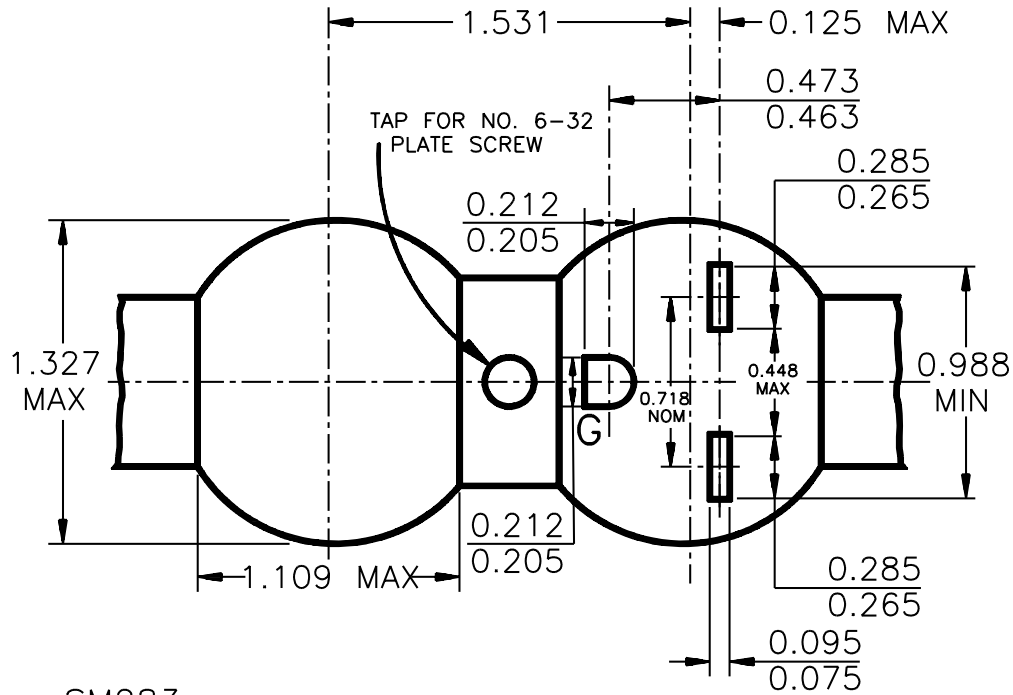

SM283

**UL COPYRIGHTED MATERIAL –
NOT AUTHORIZED FOR FURTHER REPRODUCTION OR
DISTRIBUTION WITHOUT PERMISSION FROM UL**

7.14 A portable cord-connected unit intended for wall mounting shall employ key hole slots or the equivalent as a mounting means.

7.15 A mounting tab shall not be provided with a direct plug-in unit unless all of the following conditions are met:

- a) The unit is intended for use on a 15-ampere, 125- or 250-volt receptacle;
- b) A screw is provided and constructed to secure the mounting tab of the unit to a duplex receptacle that has a center screw (see Figure 7.2);
- c) For a unit without a grounding pin, the mounting tab is constructed so that the unit may be mounted to both grounding and nongrounding receptacles; and
- d) The unit is marked as specified in 52.4.

7.16 The enclosure of a unit shall be capable of being gripped for removal from the receptacle to which it is connected, and the perimeter of the face section from which the blades project shall not be less than 0.20 inch (5.1 mm) from any point on either blade. In order to determine compliance with this requirement for units with rounded edges, the perimeter of the face section is considered to be the point at which the articulate probe is able to access as shown in Figure 7.5.

Exception: For products that are intended for use with children's toys, this distance shall be increased to 7.9 mm, as required in the Standard for Toy Transformers, UL 697. These products shall be marked "intended for use with children's toys," or an equivalent marking.

7.17 With reference to 7.16, for an extension from the face for mechanical support of the blades provided as shown in Figure 7.4, the point of measurement shall be determined by application of the articulate probe, Figure 16.2, as shown in Figure 7.5.

Figure 7.4
Extension for mechanical support of blades

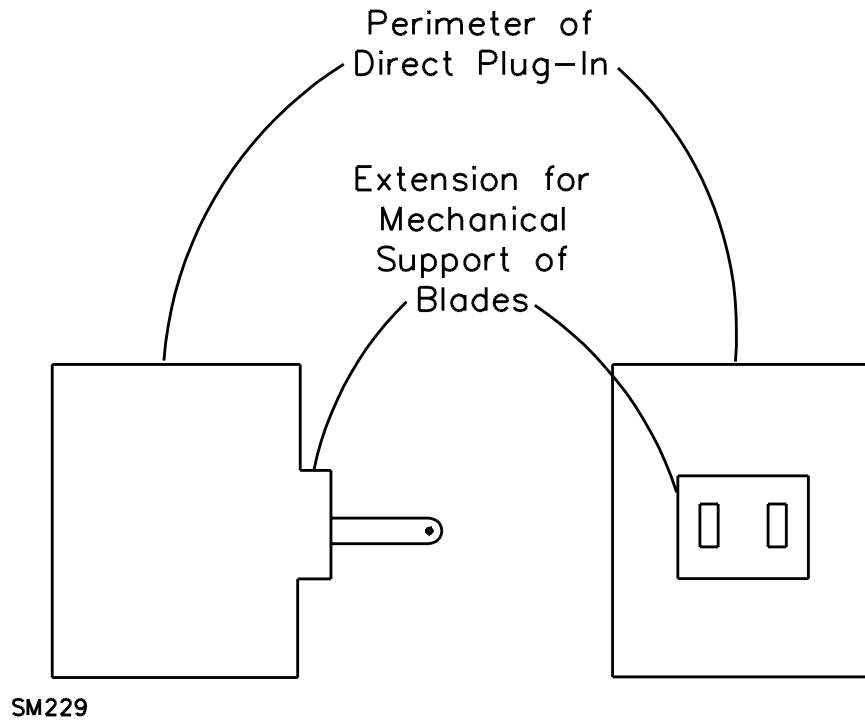
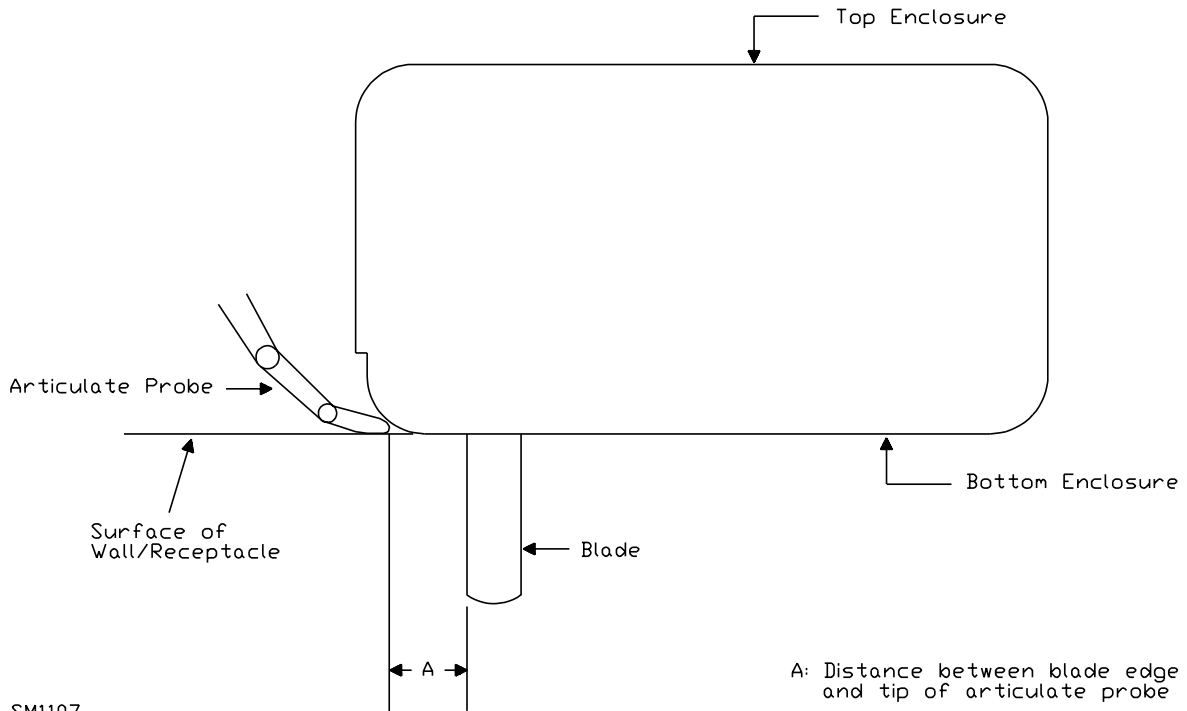

Figure 7.5
Determination of perimeter of units with rounded edges



SM1107

**UL COPYRIGHTED MATERIAL –
NOT AUTHORIZED FOR FURTHER REPRODUCTION OR
DISTRIBUTION WITHOUT PERMISSION FROM UL**

7.18 With reference to 7.16, for a direct plug-in unit employing removable blades for the input connectors, the measurement shall also be determined on the plug module while removed from the direct plug-in unit.

8 Enclosure

8.1 A unit shall be provided with an enclosure that shall house all current-carrying parts that pose a risk of electric shock. The enclosure shall have the strength and properties necessary to reduce the risk of mechanical damage to the various parts.

8.2 A unit shall have no openings larger than those complying with 16.2.1.

8.3 If an acceptable grade of vulcanized fiber is used as part of the enclosure for the support of secondary parts (terminals and the like) that do not present a risk of fire or electric shock, the amount of fiber shall not be more than is necessary to support the secondary parts in question. The fiber shall not be less than 1/32 inch (0.8 mm) thick and shall not introduce a risk of fire, electric shock, or injury to persons as a result of abuse. See 46.1.1.

8.4 An enclosure constructed of sheet metal shall be formed from stock having a thickness not less than that specified in Table 8.1. The thickness of enclosure sheet metal other than steel or aluminum shall not be less than that specified in Table 8.1 for uncoated steel and shall have the necessary strength and rigidity.

Exception: For transformers with end bells forming part of the enclosure, sheet steel having a thickness of not less than 0.020 inch (0.51 mm) if uncoated, or 0.023 inch (0.58 mm) if zinc coated, may be used if the drawn end bells have maximum dimensions of 2-1/4 inches (57.2 mm) on the flat portion and 1-1/2 inches (38.1 mm) at the base of the drawn portion.

Table 8.1
Minimum acceptable thickness of enclosure metal

Metal	At small, flat, unreinforced surfaces and at surfaces of a shape or size to provide adequate mechanical strength		At relatively large unreinforced flat surfaces	
	Inches	(mm)	Inches	(mm)
Die-cast	3/64	(1.2)	5/64	(2.0)
Cast malleable iron	1/16	(1.6)	3/32	(2.4)
Other cast metal	3/32	(2.4)	1/8	(3.2)
Uncoated sheet steel	0.026	(0.66)	0.026	(0.66)
Galvanized sheet steel	0.029	(0.74)	0.029	(0.74)
Nonferrous sheet metal other than copper	0.036	(0.91)	0.036	(0.91)
Copper	0.033	(0.84)	0.033	(0.84)

8.5 In addition to the performance tests specified in this Standard, the factors to be considered when evaluating a polymeric enclosure are:

- a) Material Flammability properties;
- b) Resistance to arcing properties; and

**UL COPYRIGHTED MATERIAL –
NOT AUTHORIZED FOR FURTHER REPRODUCTION OR
DISTRIBUTION WITHOUT PERMISSION FROM UL**

c) Moisture absorptive properties.

These properties shall comply with the requirements in the Standard for Polymeric Materials – Use in Electrical Equipment Evaluations, UL 746C. For the purpose of this requirement, a semipermanent mounted unit is to be considered a portable unit.

8.6 A conductive coating applied to a nonmetallic surface such as the inside surface of a cover, enclosure, and the like shall comply with the appropriate requirements in the Standard for Polymeric Materials – Use in Electrical Equipment Evaluations, UL 746C, unless it can be determined that flaking or peeling of the coating does not result in a reduction of spacings or the bridging of live parts that may result in a risk of fire, electric shock, or injury to persons.

8.7 An adhesive used in the assembly of the enclosure shall be investigated as specified in the Standard for Polymeric Materials – Use in Electrical Equipment Evaluations, UL 746C.

Exception: A method utilizing fusion techniques, such as solvent cementing, ultrasonic welding, electromagnetic induction, and thermal welding need not be investigated.

9 Protection Against Corrosion

9.1 Except as noted in 9.2, iron and steel parts shall be protected against corrosion by galvanizing, plating, enameling, or other equivalent means if the corrosion of such unprotected parts results in a risk of fire, electric shock, or injury to persons.

Exception: This requirement does not apply to a part made of stainless steel.

9.2 The requirement in 9.1 applies to all enclosing cases or to other parts upon which intended mechanical operation may depend. It does not apply to laminations and small minor parts of iron or steel, such as washers, screws, and bolts, that are not current carrying, if the corrosion of such unprotected parts would not result in a risk of fire, electric shock, or injury to persons, or result in the device not operating as intended.

10 Switches

10.1 The requirements in this Section apply to switches not in a Class 2 circuit, and to switches in a Class 2 circuit the breakdown of which electrically or mechanically is likely to introduce a risk of fire or electric shock.

10.2 A switch subjected to a temperature higher than 50°C (122°F) shall be evaluated with respect to the temperature limits of the materials used.

10.3 A switch shall be located and positioned so that it is not subject to mechanical damage during normal use or as a result of abuse. See 46.1.1.

10.4 Other than as indicated in 10.7 and 10.8, a switch or other control device shall be acceptable for the application and shall have current and voltage ratings not less than those of the load that it controls.

10.5 A primary circuit switch shall be connected to an ungrounded circuit conductor.

10.6 A primary circuit switch shall have a current rating not less than twice the normal current draw under normal load conditions, or the switch shall be investigated for the application in accordance with the Overload and Endurance Tests on Switches and Controls, Section 36.

10.7 A switch or other control device connected in the output circuit may be used if the device complies with the Normal Temperature Test and the Overload Test on Secondary Switches. See 33.1 and 37.1.

10.8 A switch or other controller not having an acceptable rating and located on a direct plug-in unit where it cannot be operated unless the unit is withdrawn from a receptacle may be used if it complies with the Operation Test, Section 38.

11 Protective Devices

11.1 A protective device built into a unit shall comply with the requirements for that component.

11.2 The protective device may be located in either the primary or secondary circuit.

11.3 Crossed or nicked (reduced) cross-section conductors shall not be employed as a protective device.

11.4 Protective devices mentioned in 11.1 include, but are not limited to, eutectic material, fuses, overtemperature and overcurrent protectors, thermal protectors, and similar devices intended to interrupt or limit the flow of current as a result of overload.

11.5 A thermostat, thermal cutoff, Positive Temperature Coefficient (PTC) resistor, or Negative Temperature Coefficient (NTC) resistor incorporated in a unit shall not cause a risk of fire or electric shock due to improper application.

11.6 A manually reset thermostat shall be constructed so that automatic tripping of the thermostat is not prevented by any setting or position of the reset mechanism.

11.7 An automatically or manually reset protective device or a replaceable overcurrent-protective device shall not open when the unit is delivering its rated output. See the Normal Temperature Test, Section 33.

11.8 A primary circuit overcurrent protective device of the single-pole type, other than an automatic control without a marked "off" position, shall be connected to an ungrounded circuit conductor. See Exception No. 5 to 14.2.1.

11.9 When a single fuse is located in the primary circuit, it shall be connected to an ungrounded circuit conductor.

Exception: This requirement does not apply to a unit not intended to be serviced.

11.10 When both circuit conductors of a product intended for connection to a nominal 120 volt branch circuit are fused, the fuse in the grounded circuit conductor shall be rated not less than the fuse in the ungrounded circuit conductor. See 52.8.

Exception: This requirement does not apply to a unit not intended to be serviced.

11.11 A unit investigated for compliance with the energy limitations of 30.3.1 shall be provided with protection, such as a fuse or PTC, complying with the Calibration of Overcurrent Protection Devices Test, Section 31.

11.12 A protective device that is provided to comply with 11.11 shall not be of the automatic reclosing type, and shall not have automatic tripping prevented by any setting or position of the reset mechanism. When an accessible control of a manual reset protective device is held in the on or reset position, and the protective device is automatically tripped, the contact shall not automatically return to the closed position.

11.13 An overcurrent protective device shall be located inside the unit enclosure. The device shall be inaccessible to tampering.

Exception: A unit may be provided with an externally replaceable overcurrent protective device. If the device is relied upon for acceptable performance, the device shall not be interchangeable with a device having a higher current rating.

11.14 A fuse provided in the secondary circuit of a not inherently limiting Class 2 power unit shall be rated in accordance with Table 30.2.

12 Components

12.1 A component – a fixed resistor, Positive Temperature Coefficient (PTC) or Negative Temperature Coefficient (NTC) resistor, diode, or the like – employed to limit (see 5.8) the output of a unit to within the required current or power levels, or otherwise used to obtain acceptable performance, shall have permanence and stability which does not decrease its limiting capacities. Among the factors considered when evaluating a limiting component are:

- a) Effect of operating temperature;
- b) Electrical stress level;
- c) Effect of transient surges; and
- d) Resistance to moisture.

12.2 There shall be no components connected between primary and output circuits which result in a conductive connection (see 5.4). If capacitive coupling is provided between primary and output circuits, it shall consist of either:

- a) A capacitor complying with the antenna coupling requirements specified in the Standard for Fixed Capacitors for Use in Electronic Equipment – Part 14: Sectional Specification: Fixed Capacitors for Electromagnetic Interference Suppression and Connection to the Supply Mains, UL 60384-14; or
- b) Two capacitors connected in series, each capacitor complying with the requirements in 34.1.3.

12.2 revised May 30, 2014

13 Coil Insulation

13.1 General

13.1.1 A coil shall be provided with insulation between the coil and any dead metal part, and between each adjacent pair of windings.

Exception No. 1: Two or more secondary windings may be considered as a single winding and interposing insulation is not required, if, when interconnected, the windings comply with the performance requirements for a single winding.

Exception No. 2: Insulation is not required if the spacings required by 24.1 are provided.

13.1.2 Coil insulation, unless inherently moisture resistant, shall be treated to render it moisture resistant.

13.1.3 Film-coated magnet wire is considered to be moisture resistant.

13.2 Insulation for transformers

13.2.1 The insulation between uninsulated, primary wires of opposite polarity shall be one of the following:

- a) Electrical grade paper, waxed or otherwise treated to resist the absorption of moisture, having a total thickness of not less than 0.012 inch (0.305 mm); or
- b) Other insulating material having a dielectric breakdown strength of not less than 2500 volts in the thickness used as determined by the Tests on Insulating Materials, Section 40.

13.2.2 Insulation between the primary and secondary windings shall be one of the following (for additional requirements, see 13.2.3 and 13.2.4):

- a) Electrical grade paper, waxed or otherwise treated to resist the absorption of moisture, having a total minimum thickness of 0.012 inch (0.305 mm).
- b) A molded polymeric material such as a coil form or bobbin having a minimum thickness of 0.025 inch (0.64 mm).
- c) Insulation – other than of a molded polymeric material – as specified in 13.2.1(b).

13.2.3 Tape used as insulation in lieu of spacings for a flanged bobbin wound transformer shall provide a continuous 1/32 inch (0.8 mm) minimum wide bent up edge against the bobbin flanges.

13.2.4 A flanged, bobbin-wound transformer shall be subjected to the output loading test described in 39.2. The test shall be continued for 15 days if the transformer has:

- a) The primary winding wound over the secondary winding or the secondary winding wound over the primary winding; and
- b) The primary winding insulated from the secondary winding by a layer of insulating material other than that specified in 13.2.2(b).

Exception: The test is not required to be applied for 15 days if the following requirements are met:

**UL COPYRIGHTED MATERIAL –
NOT AUTHORIZED FOR FURTHER REPRODUCTION OR
DISTRIBUTION WITHOUT PERMISSION FROM UL**

- a) *Multiple layered winding wire is used, which has been evaluated to the requirements for miscellaneous insulating devices and materials of the Standard for Polymeric Materials – Short Term Property Evaluations, UL 746A, the Standard for Polymeric Materials – Long Term Property Evaluations, UL 746B, and the Standard for Polymeric Materials – Use in Electrical Equipment Evaluations, UL 746C;*
- b) *The spacing requirements of Table 24.1 and Table 24.2 are met;*
- c) *The requirements in the Standard for Insulation Coordination Including Clearances and Creepage Distances for Electrical Equipment, UL 840, are met, along with the use of additional securement of the winding, and a Comparative Tracking Index (CTI) rating of 100 for all insulating material is determined; or*
- d) *Insulated wiring is used which has been evaluated to the Standard for Single- and Multi-Layer Insulated Winding Wire, UL 2353.*

13.2.5 Insulation between the primary winding and the core shall be one of the following:

- a) *Electrical grade paper, waxed or otherwise treated to resist moisture, having a minimum total thickness of 0.012 inch (0.305 mm).*
- b) *A molded polymeric material such as a coil form or bobbin having a minimum thickness of 0.025 inch (0.64 mm).*
- c) *Insulation – other than of a molded polymeric material – as specified in 13.2.1(b).*

Exception: Insulation may be reduced or waived between the primary and core when all of the following conditions are met:

- a) *The core is of a low electrical conductance material, for example ferrite used in switch-mode product;*
- b) *The core is treated as a live and electrically conductive part when judging insulation and spacings between the core and:*
 - i) *Accessible metal parts;*
 - ii) *The secondary windings; and*
 - iii) *Any other output circuitry.*
- c) *In applying (b), the core shall be considered to be at the maximum potential of the primary winding; and*
- d) *Insulation between secondary windings and core are in accordance with 13.2.5.*

13.2.6 Insulation between the primary winding lead connections and a metallic enclosure shall be one of the following:

- a) Electrical grade paper, waxed or otherwise treated to resist the absorption of moisture, not less than 0.012 inch (0.305 mm) thick if used in conjunction with an air spacing of one-half that specified in 24.1.
- b) Electrical grade paper, waxed or otherwise treated to resist the absorption of moisture having a total thickness of not less than 0.028 inch (0.71 mm) when the insulation is in contact with the enclosure.
- c) Insulation having a dielectric breakdown strength of not less than 2500 volts in the thickness used for (a) and 5000 volts in the thickness used for (b) as determined by Tests on Insulating Materials, Section 40.

13.2.7 Insulation in accordance with 13.2.8 shall be provided between a crossover lead and:

- a) The turns of the winding to which it is connected;
- b) The adjacent winding;
- c) The metallic enclosure; and
- d) The core.

13.2.8 To comply with 13.2.7, insulation shall be one of the following:

- a) Electrical grade paper, waxed or otherwise treated to resist the absorption of moisture, having a total thickness of not less than 0.012 inch (0.305 mm); or
- b) Insulation as specified in 13.2.1(b).

Exception No. 1: Any type or thickness of insulation, or a through air spacing less than specified in 24.1, between a crossover lead and the winding to which it is connected may be used if either:

- a) The coil withstands the dielectric voltage withstand test described in 34.1.1 and 34.1.2 with the potential applied between the coil leads and with the coil lead cut at the point where it enters the inner layer; or*
- b) The coil withstands the induced potential test described in 34.2.1 – 34.2.3. See 13.2.9.*

Exception No. 2: This requirement does not apply to insulation between a Class 2 secondary crossover lead and:

- a) The secondary winding to which the crossover lead is connected;*
- b) The metallic enclosure; and*
- c) The core.*

13.2.9 With reference to Exception No. 1 to 13.2.8, the magnet coil of a molded bobbin transformer having a slot for the crossover or start lead – unspliced at the windings – is acceptable as crossover lead insulation if:

- a) The slots provide a graduated through air spacing to the winding, increasing to the end turns; and
- b) The magnet-coil winding withstands the induced potential test described in 34.2.1 – 34.2.3 or the dielectric voltage withstand test described in 34.1.1 and 34.1.2.

13.2.10 Insulation between the primary-lead connections and the adjacent winding, and between secondary-lead connections and the primary winding shall be one of the following:

- a) Electrical grade paper, waxed or otherwise treated to resist the absorption of moisture, having a total thickness of not less than 0.028 inch (0.71 mm); or
- b) Other insulating material having a dielectric breakdown strength of not less than 5000 volts in the thickness used as determined by Tests on Insulating Materials, Section 40.

14 Input Connections

14.1 Direct plug-in units

14.1.1 The integral blade assembly of direct plug-in units shall comply with the construction requirements in the Standard for Attachment Plugs and Receptacles, UL 498, and Wiring Devices – Dimensional Specifications, ANSI/NEMA WD6. See 7.16 and 7.17.

14.1.2 If a direct plug-in unit employs a manually operated line connected single-pole switch or a fuse with an accessible contact, it shall employ a polarized- or grounding-type blade assembly.

14.1.3 If a direct plug-in unit employs removable, folding or retractable blades for the input connectors, it shall comply with the requirements specified in Section 44, Direct Plug-in Security of Input Contacts Test.

14.1.4 A power unit intended for use by travelers shall comply with (a) – (e):

- a) The blade assembly shall be a 125 volt, 15 amp configuration;
- b) The power unit shall employ a user adjustable voltage selector and comply with 39.6.1, or be capable of operating at different voltages without user adjustment;
- c) The input voltage rating shall include nominal 120 volt;
- d) The power unit shall be marked as specified in 51.8; and
- e) The power unit shall be provided with instructions as specified in 54.4.

14.2 Cord-connected units

14.2.1 A portable or stationary unit shall be provided with a flexible cord in accordance with Table 14.1 and an attachment plug for connection to the branch circuit. The blade assembly for connection to the branch circuit shall be of the polarized- or grounding-type. The length of cord external to the unit and including the attachment plug shall not be less than 6 feet (1.8 m) as measured from the face of the attachment plug to the point of attachment or entry.

Exception No. 1: A unit weighing 1 pound (454 g) or less is acceptable if the total length of the input and output cords is 6 feet or more, and the length of the input cord is at least 3 feet (0.91 m).

Exception No. 2: A stationary power unit intended to be fastened in place may require a form of supply connection that facilitates the interchange of equipment to maintain continuous service or otherwise meet special conditions of use. For such service, a Type S, SE, or equivalent flexible cord may be employed and may be of a length appropriate for the purpose, but no longer than 10 feet (3 m). Normally, a 2 foot (610 mm) length of cord will be sufficient for the plug and the receptacle connection.

Exception No. 3: A power unit marked in accordance with 51.7 and provided with instructions in accordance with 54.3 is not required to be provided with the detachable power supply cord.

Exception No. 4: If a power unit is intended for use in a country other than the U.S.A, the detachable power supply cord shall comply with the requirements of the country of destination.

Exception No. 5: For products that do not require a discharge path, a cord connected unit is not required to be supplied with a polarized plug when it does not include any single pole switches or fuseholders with accessible contacts.

Table 14.1
Acceptable flexible cords for cord connected power units

Flexible cord type	Maximum length, feet (m)
At least as serviceable as SP-2, SPE-2, SPT-2, SV, SVE, SVT	10 (3)
At least as serviceable as S, SE, SO, SP-3, SPT-3, ST, STO, SJ, SJE, SJO, SJT, SJTO	Not specified

14.2.2 If a unit with a permanently attached power supply cord can be adapted for use on two or more different voltages by field alteration of internal connections, the attachment plug provided with the unit shall be of a type required for the voltage and current for which the unit is connected when shipped from the factory.

14.2.3 If a multiple voltage rated power unit is intended for use with a detachable power supply cord, the cord shall be provided with the unit if either of the following apply:

- a) The power unit is provided with an operator adjustable voltage selector and complies with 39.6.1; or
- b) The power unit is capable of operating at different voltages without user adjustment.

The power unit shall be provided with instructions in accordance with 54.1 and 54.2.

Exception: A power unit marked in accordance with 51.7 and provided with instructions in accordance with 54.3 is not required to be provided with the detachable power supply cord.

UL COPYRIGHTED MATERIAL –
NOT AUTHORIZED FOR FURTHER REPRODUCTION OR
DISTRIBUTION WITHOUT PERMISSION FROM UL

14.2.4 A power unit intended for use by travelers shall comply with (a) – (e):

- a) The power supply cord shall terminate in a 125 volt, 15 amp plug configuration;
- b) The power unit shall employ a user adjustable voltage selector and comply with 39.6.1, or be capable of operating at different voltages without user adjustment;
- c) The input voltage rating shall include nominal 120 volt;
- d) The power unit shall be marked as indicated in 51.8; and
- e) The power unit shall be provided with instructions per 54.4.

14.3 DC input units

14.3.1 Units with a dc input shall be provided with a vehicle battery adapter in compliance with the Standard for Vehicle Battery Adapters, UL 2089, or with a cable as specified in 76.1.

Exception: A vehicle battery adapter is not required to be provided with the unit, when the unit is marked for use with a required vehicle battery adapter complying with the Standard for Vehicle Battery Adapters, UL 2089.

14.3.2 A fuse provided with a dc input jack shall not be relied upon to provide the overcurrent protection specified in the Output Current and Power Test, Section 30.

14.3.3 A unit employing an integral cigarette lighter connector assembly shall also comply with the Standard for Vehicle Battery Adapters, UL 2089. In addition, the overall mass of the unit shall not exceed 250 g (8.8 oz). The product of the total mass, and the distance between the center of gravity and the input contact positioned to simulate full insertion into a vehicle power outlet, shall not exceed 13500 g-mm (18.7 oz-in). For a unit with an attached cord, the determination shall be made with the cord severed at the enclosure, or at the strain-relief means if the strain-relief means is outside the enclosure. For a unit with a detachable cord, the determination shall be made with the cord severed from the mating connector connected to the cigarette lighter connector.

15 Output Connections

15.1 General

15.1.1 A unit shall be provided with an output cord, terminals, insulated leads, or output connectors. A battery charger with backfeed protection shall be provided with an output cord terminating in a connector, or a connector attached to or integral with the enclosure. See 15.4.3.

15.2 Output wiring

15.2.1 The output wiring shall be stranded conductors having insulation not less than 0.013 inch (0.33 mm) thick, and permanently attached to the output circuit. The wiring shall extend at least 6 feet (1.8 m) outside the unit, and shall comply with the requirements in 18.1 and 18.2.

Exception No. 1: Wiring less than 6 feet long may be used if longer wiring introduces a risk of fire, electric shock, or injury to persons.

Exception No. 2: A product covered by Exception No. 1 to 14.2.1 need not extend the output wiring 6 feet (1.8 m) outside the unit.

15.2.2 For a cord-connected power unit with a minimum 6-foot (1.8-m) power-supply cord, the output flexible cord required by 15.1.1, whether permanently attached to the power unit or provided in the form of a separate cord set, shall be of any desirable length. The maximum combined length of the input and output cords shall not exceed 20 feet (6.1 m).

15.2.3 With respect to 15.2.1, for units with jacketed multiconductor output wiring, the individual conductor insulation may be less than 0.013 inch (0.33 mm) provided that the following conditions are met:

- a) The thickness of the individual conductor insulation plus the thickness of the jacket is not less than 0.013 inch; and
- b) The unit complies with the requirements in 28.1 and 30.2.1 with any combination of output conductors interconnected.

15.2.4 A fitting having female contacts shall be constructed so that it does not receive the blades of a standard attachment plug. A fitting having male contacts shall be constructed so that the contacts do not touch a live part of a standard attachment-plug receptacle.

15.3 Output terminals

15.3.1 A terminal plate tapped for a wire-binding screw or stud shall be of brass or other nonferrous metal, or plated steel, not less than 0.030 inch (0.76 mm) thick, and shall provide not less than two full threads in the metal for the binding screw.

Exception No. 1: Two full threads are not required if a lesser number of threads results in a secure connection in which the threads do not strip when subjected to the test specified in 45.1.

Exception No. 2: A plate may be less than 0.030 inch thick if the tapped threads have acceptable mechanical strength. See 45.1.

Exception No. 3: This requirement does not apply to a terminal plate that complies with the Exception to 45.1.

**UL COPYRIGHTED MATERIAL –
NOT AUTHORIZED FOR FURTHER REPRODUCTION OR
DISTRIBUTION WITHOUT PERMISSION FROM UL**

15.3.2 A wire-binding screw or terminal stud shall not be smaller than No. 6 (3.5 mm diameter) and shall not have more than 32 threads per inch (25.4 mm). The screw or stud shall be of brass or other nonferrous metal, or plated iron or steel.

15.3.3 Terminal studs shall be prevented from turning by means other than friction between mounting surfaces. The acceptability of a lock washer or similar means to prevent turning shall be determined by the test described in 45.1 and 45.2.

15.3.4 A multi-output unit employing output terminals the output of which exceeds the current limit specified in 30.2 with outputs interconnected shall be marked in accordance with 52.12.

15.4 Output connectors

15.4.1 A unit with multiple outputs where interconnection exceeds Class 2 levels as defined in this standard shall be provided with a polarized connector.

15.4.2 Output connectors mounted on the enclosure and intended for direct connection of accessories, such as separable battery holders and the like, shall provide a secure connection between mating parts. The connections shall be polarized if the output is direct-current or if multiple outputs are provided.

15.4.3 A battery charger shall be provided with a means to inhibit backfeed of current during a fault in the output circuit, including faults in the output wiring, which results in a risk of fire or electric shock. The means of prevention shall protect each output and shall consist of any of the following:

- a) A fuse, calibrated in accordance with the Standard for Low-Voltage Fuses – Part 1: General Requirements, UL 248-1, and the Standard for Low-Voltage Fuses – Part 14: Supplemental Fuses, UL 248-14, located in the output connector and rated to correspond with the maximum overcurrent protection rating in Table 30.2 for the open circuit voltage involved;
- b) A diode or fixed impedance located in the output connector where it will limit backfeed current in accordance with the test specified in 39.9.1 and 39.9.2;
- c) An overcurrent protector equivalent to (a) located in the output connector; or
- d) An output cord equivalent to that specified in Table 14.1 with respect to insulating material and thickness; and the battery charger complies with the test specified in 39.9.3 and 39.9.4.

Exception No. 1: A means of protection is not required when a specific battery or battery pack, to be used with the charger, does not exceed Class 2 parameters at any level of charge condition. See 52.9. If the specific battery or battery pack employs limiting circuitry, it shall either:

- a) Comply with Class 2 parameters with all circuitry defeated; or*
- b) Comply with the Standard for Household and Commercial Batteries, UL 2054.*

Exception No. 2: A battery charger employing integral batteries is not required to comply with 15.4.3.

15.4.3 revised October 11, 2013

15.4.4 Connectors normally used with coaxial cable shall not be used for output connections.

15.5 Bushings

15.5.1 At a point where a flexible cord passes or is intended to pass through an opening in a metal wall, barrier, or enclosing case, there shall be a bushing or the equivalent that shall:

- a) Be substantial;
- b) Be secured in place; and
- c) Have a smooth, rounded surface against which the cord may bear.

15.5.2 If the cord hole is in a nonconducting material, a smooth, rounded surface is considered to be the equivalent of a bushing.

16 Accessibility of Live Parts

16.1 General

16.1.1 A live part that poses a risk of electric shock shall be located or enclosed so that the risk of contact is reduced.

16.1.2 The input impedance of the voltmeter used to measure voltage in accordance with the requirements of 16.2.1 and 16.3.1 is to be a minimum of one megohm. The input impedance of a meter with more than one megohm input impedance can be lowered by using shunt impedance.

16.1.3 A guard, baffle, or cover that can be removed without using a tool is to be removed when determining if a live part is accessible to the user. A live part that can be contacted by the test pin, articulate probe, or accessibility probe illustrated in Figure 16.1, Figure 16.2, or Figure 16.4 is considered to be accessible.

Exception: For direct plug-in units provided with removable blades for the input connectors, accessibility of live parts shall also be determined on the plug module while removed from the direct plug-in unit, even if tools are required for removal.

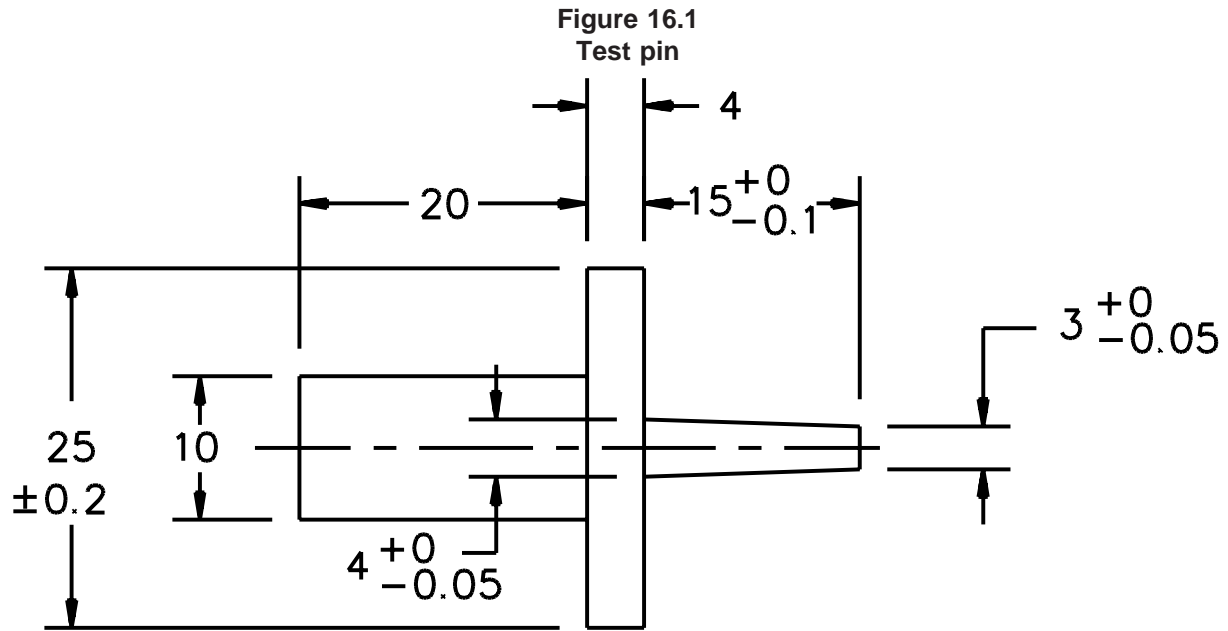

S2962

Dimensions in millimeters

Figure 16.2
Articulate probe with web stop

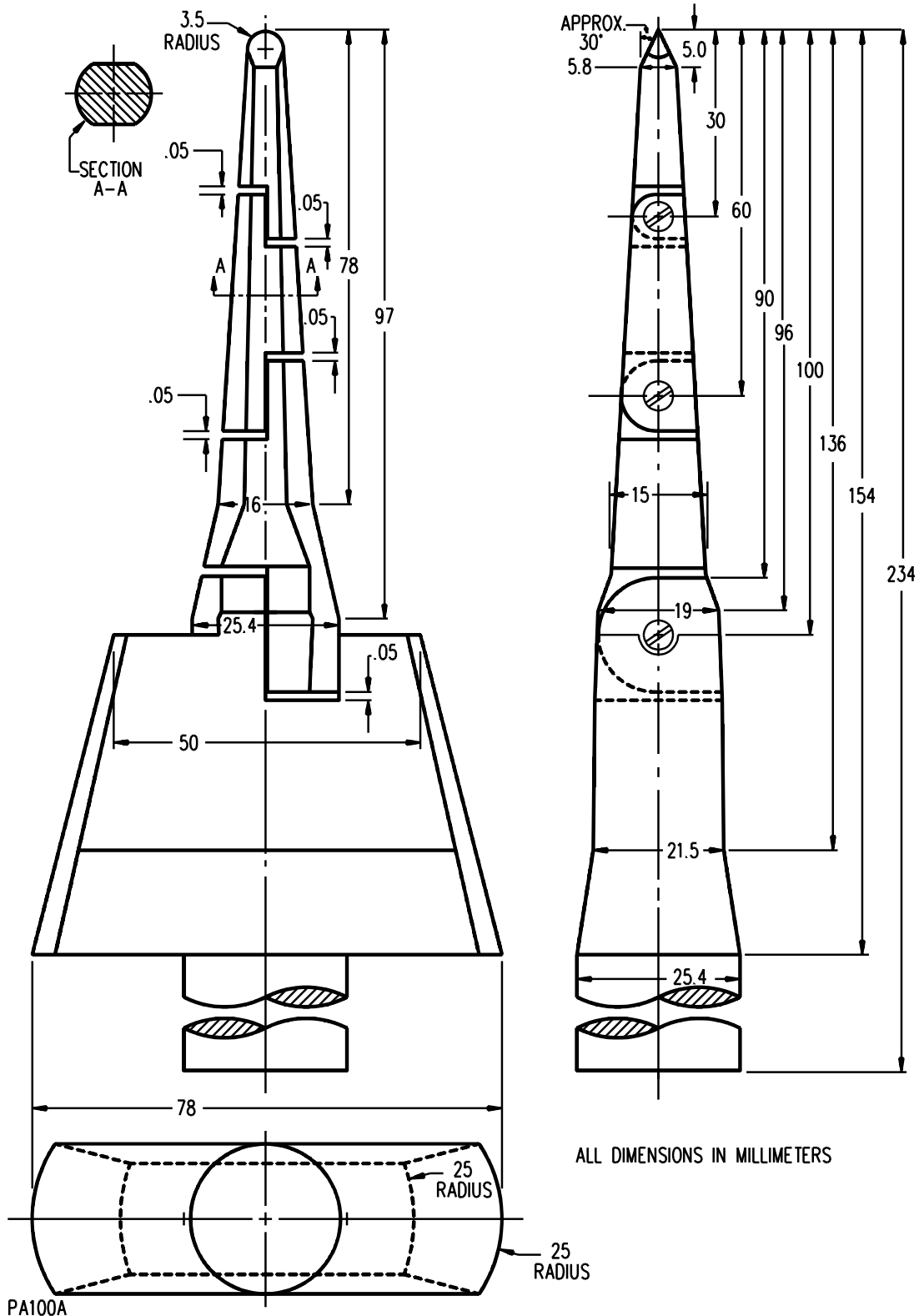

UL COPYRIGHTED MATERIAL –
NOT AUTHORIZED FOR FURTHER REPRODUCTION OR
DISTRIBUTION WITHOUT PERMISSION FROM UL

16.2 Live parts other than exposed wiring terminals

16.2.1 The test pin and articulate probe illustrated in Figures 16.1 and 16.2, respectively, when applied as indicated in 16.2.2, shall not contact:

- a) A primary circuit; or
- b) Any live part with a voltage greater than that specified in 16.2.2 with respect to ground or any other live part simultaneously accessible to the test pin or articulate probe.

16.2.2 The maximum voltages which may be accessible in accordance with 16.2.1(a) are:

- a) 42.4 V peak for sinusoidal or nonsinusoidal AC;
- b) 60 V for continuous DC, or 60 V peak for interrupted DC outside the range of 10 – 200 Hz;
- c) 24.8 V peak for DC interrupted at a rate of 10 – 200 Hz; and
- d) As indicated in Figure 16.3 for combinations of AC and DC.

For the purpose of this requirement, initial transients lasting less than 200 milliseconds may be ignored. Since short term peak voltage is of interest during tests involving a fault, voltages are to be monitored by using a storage oscilloscope for the first two seconds after any fault is introduced.

Exception: The voltage may be exceeded if the current between the parts does not exceed 0.5 mA when measured in accordance with Leakage Current Test, Section 26.

16.2.2 revised October 11, 2013

Figure 16.3
Maximum acceptable voltage

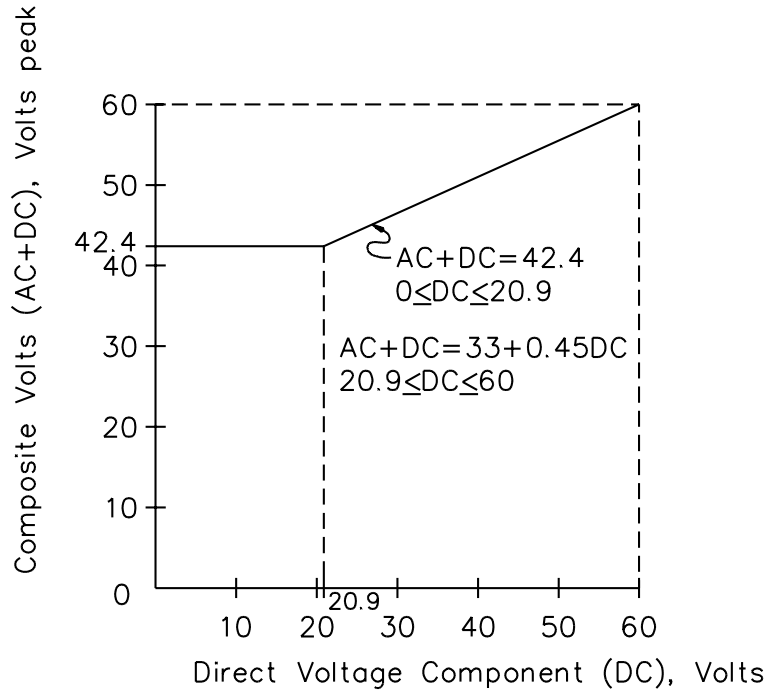
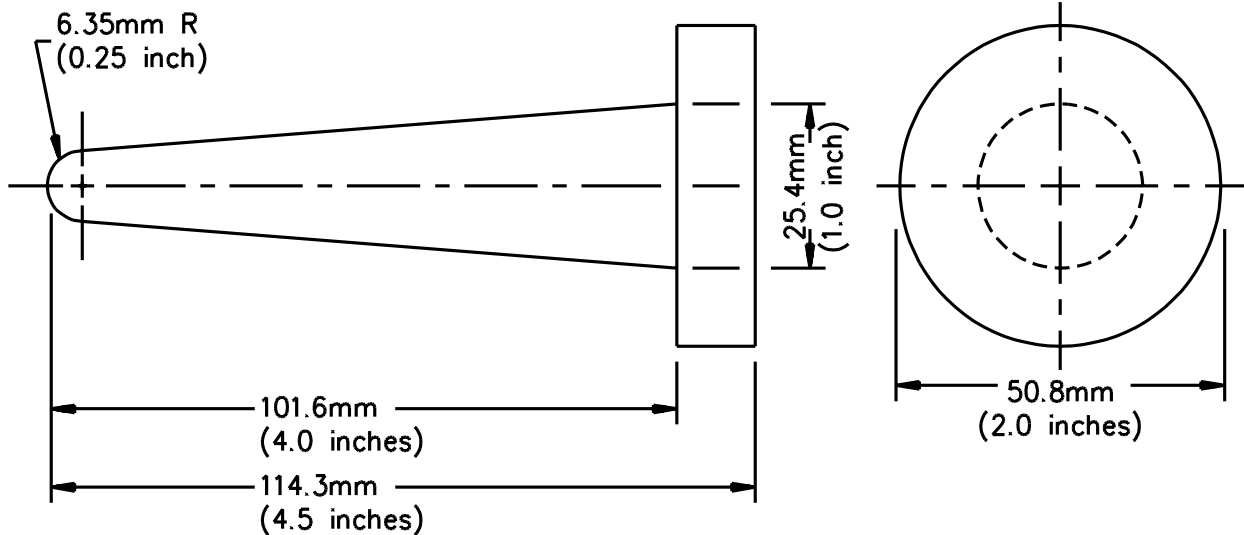

Figure 16.4
Accessibility probe



16.2.3 The test pin and articulate probe referenced in 16.2.1 are to be applied with a force not exceeding 1 pound (4.4 N) to determine whether the live parts are accessible. The test pin shall not be applied to fuseholders and the like.

16.3 Exposed wiring terminals

16.3.1 The accessibility probe illustrated in Figure 16.4, when applied as indicated in 16.3.3, shall not contact an exposed wiring terminal with a voltage greater than that specified in 16.3.2 with respect to ground or to any other terminal simultaneously accessible to the probe.

16.3.2 The maximum voltages which may be accessible in accordance with 16.3.1 are:

- a) 42.4 V peak for sinusoidal or nonsinusoidal AC;
- b) 42.4 V for continuous DC, or 42.4 V peak for interrupted DC outside the range of 10 – 200 Hz;
- c) 24.8 V peak for DC interrupted at a rate of 10 – 200 Hz; and
- d) 42.4 V peak for combinations of AC and DC.

16.3.2 revised October 11, 2013

16.3.3 The accessibility probe referenced in 16.3.1 is to be applied with a force not exceeding 5.62 pounds (25 N) to determine whether the exposed wiring terminals are accessible. Prior to applying the probe, wire binding screws are to secure the largest wire in accordance with Table 45.1.

17 Live Parts

17.1 A current-carrying part shall be silver, copper, a copper alloy, plated iron or steel, stainless steel, or other corrosion-resistant alloys acceptable for the application.

17.2 An uninsulated live part shall be secured to the base or mounting surface so that it does not turn or shift in position if such motion results in a reduction of spacings below the minimum acceptable values.

17.3 Friction between surfaces is not acceptable as a means to prevent shifting or turning of a live part but a lock washer is acceptable.

18 Strain Relief

18.1 Strain relief shall be provided for the supply cord and output wiring, and shall be tested in accordance with the Strain Relief Test, Section 41.

18.2 Means shall be provided to prevent the cord or wiring from being pushed into the enclosure through the cord-entry hole when such displacement results in:

- a) Subjecting the supply cord or lead to mechanical damage;
- b) Exposing the supply cord or lead to a temperature higher than that for which it is rated;
- c) Reducing spacings (such as to a metal strain-relief clamp) below the minimum required values; or
- d) Damaging internal connections or components.

To determine compliance, the supply cord or lead shall be tested in accordance with Section 42, Push-Back Relief Test.

19 Internal Wiring

19.1 The internal wiring of a unit shall consist of insulated conductors having mechanical strength, dielectric properties, and ampacity for the application. See 19.6.

19.2 Each splice and connection shall be mechanically secure, shall provide reliable electrical contact, and shall be provided with insulation at least equivalent to that of the wire involved unless acceptable permanent spacing between the splice and all other metal parts will be maintained. When determining the required minimum thickness of splice insulation, the circuit voltage and interaction with other circuits shall be taken into consideration.

19.3 A wire connector for making a splice in a unit shall be a type that is applied by a tool in which the application force of the tool making the splice is independent of the force applied by the operator of the tool.

19.4 The connection between a lead, including a flexible cord, and the transformer winding or other part of the unit shall be soldered, welded, or otherwise securely connected within the enclosure. A soldered joint shall be mechanically secure before soldering.

19.5 If a lead is rigidly held in place without the use of solder, or if it is retained in place so as not to be subjected to any motion, no additional mechanical security is required. Mechanical securement of a lead is not required if separation of the connection does not result in a risk of fire or electric shock.

19.6 Unless it is to be evaluated as an uninsulated live part, insulated internal wiring – including an equipment-grounding conductor – shall consist of wire of a type or types acceptable for the application, when considered with respect to:

- a) The temperature and voltage to which the wiring is likely to be subjected;
- b) Exposure to oil, grease, cleaning fluid, or other substances likely to have a deleterious effect on the insulation; and
- c) Other conditions of service to which it is likely to be subjected.

UL COPYRIGHTED MATERIAL –
NOT AUTHORIZED FOR FURTHER REPRODUCTION OR
DISTRIBUTION WITHOUT PERMISSION FROM UL

19.7 An insulated conductor shall be located or protected to reduce the risk of contact with any sharp edge, burr, fin, moving part, or the like, that can damage the conductor insulation.

20 Separation of Circuits

20.1 Unless provided with insulation rated for the highest voltage involved, insulated conductors of different circuits – internal wiring – shall be separated by barriers or shall be segregated and shall, in any case, be separated or segregated from uninsulated live parts connected to different circuits.

20.2 Segregation of insulated conductors may be accomplished by clamping, routing, or equivalent means that provides permanent separation from an insulated or uninsulated live part of a different circuit.

20.3 A barrier used to separate or segregate internal wiring shall have mechanical strength and be held in place to provide permanent separation, and it shall be acceptable for the temperatures involved.

20.4 A barrier intended to separate or segregate low-voltage field wiring from line-voltage parts shall be of material of sufficient thickness to serve its intended purpose. It shall be supported so that its deformation cannot be readily accomplished to defeat its purpose.

21 Insulating Materials

21.1 Integral parts such as insulating washers and bushings, and bases or supports for mounting of live parts, shall be of moisture-resistant materials that are not damaged by the temperatures and stresses to which they are subjected under conditions of actual use.

21.2 An insulating material is to be evaluated for the application in accordance with the Standard for Polymeric Materials – Use in Electrical Equipment Evaluations, UL 746C. Consideration is to be given to such factors as its mechanical strength, resistance to ignition sources, dielectric strength, insulation resistance, and heat-resistant properties in both the aged and unaged conditions, the degree to which it is enclosed, and any other features affecting the risk of fire and electric shock.

Exception: Materials, such as mica, ceramic, or some molded compounds are usually acceptable for use as the sole support of live parts.

22 Printed-Wiring Boards

22.1 A printed-wiring board in a unit shall comply with the Standard for Printed-Wiring Boards, UL 796, and shall be classed V-1 or less flammable, in accordance with the Standard for Tests for Flammability of Plastic Materials for Parts in Devices and Appliances, UL 94.

Exception No. 1: This requirement does not apply to a printed-wiring board that contains only Class 2 circuits where deterioration or breakage of the bond between the conductor and the base material does not result in a risk of fire or electric shock.

Exception No. 2: For a direct plug-in unit, a V-2 material may be used if the enclosure has no openings.

Exception No. 3: For a cord-connected unit, a V-2 material may be used if the unit is closed beneath the material or has an equivalent barrier.

22.2 A resistor, capacitor, inductor, or other part that is mounted on a printed circuit board to form a printed circuit assembly shall be secured so that it cannot be displaced to cause a risk of fire or electric shock by a force likely to be exerted on it during assembly or normal operation as determined during the Abuse Tests, Section 46.

22.3 A printed-wiring board as indicated in Exception No. 1 to 24.1 shall also:

- a) Comply with the Standard for Printed-Wiring Boards, UL 796; and
- b) Have a minimum flammability classification of V-0 in accordance with the Standard for Tests for Flammability of Plastic Materials for Parts in Devices and Appliances, UL 94.

23 Grounding

23.1 General

23.1.1 Provision shall be made for grounding of all dead metal parts that are exposed or that are likely to be touched by a person during intended operation or adjustment of the unit, and that are likely to become energized through electric fault.

Exception: A metal part, such as an adhesive-attached metal foil marking, a screw, or a rivet separated from wiring and spaced from uninsulated live parts as if it were a grounded part need not be connected to the grounding member.

23.1.2 For a direct plug-in unit intended for semipermanent installation, a metal mounting tab may serve as the grounding member.

23.1.3 A metallic ground pin, if employed, shall be conductively connected to accessible metal parts. For units not having accessible dead metal parts, the grounding means shall be connected to:

- a) The core of the transformer or other internal dead metal part;
- b) The transformer secondary output; or
- c) A grounding wire in the output cord which terminates at the output connector.

For a direct plug-in unit provided with a non-metallic ground pin, see 23.1.7.

23.1.3 revised October 30, 2013

23.1.4 With reference to 23.1.3(c), for units having the grounding means connected to a bonding wire in the output cord, the bonding wire shall comply with 23.2.6.

23.1.5 To determine whether a part is likely to become energized, such factors as construction, the proximity of wiring, a dielectric voltage withstand test after the overload and endurance tests, a burnout test, and similar considerations are to be evaluated.

23.1.6 Bonding shall comply with 23.2 whether the grounding connection is required or not. A soldering lug, a screwless (push-in) connector, a quick-connect, or other friction-fit connector shall not be used. A sheet metal screw shall not be used to connect a grounding conductor or connection device to an enclosure.

Exception: A quick-connect terminal may be used in conjunction with solder for securing the grounding conductor.

23.1.7 A direct plug-in unit provided with a non-metallic ground pin for increased stability (dummy ground pin) shall comply with 23.1.8 and, if applicable, 23.1.9.

23.1.7 added October 30, 2013

23.1.8 The orientation of the non-metallic ground pin with respect to the supply blades shall be in accordance with Figure 7.2 or 7.3.

23.1.8 added October 30, 2013

23.1.9 A direct plug-in unit intended for use with a duplex receptacle where a non-metallic ground pin is oriented for insertion in the grounding contact of the receptacle adjacent to that used for the supply blades shall:

- a) Render the supply contacts of the receptacle adjacent to that associated with the direct plug-in supply blades completely unusable; and
- b) Be provided with the following marking or instruction:
 - 1) "For use only with a duplex receptacle" or equivalent; or
 - 2) A pictorial illustrating proper orientation in a duplex receptacle.

23.1.9 added October 30, 2013

No Text on This Page

***UL COPYRIGHTED MATERIAL –
NOT AUTHORIZED FOR FURTHER REPRODUCTION OR
DISTRIBUTION WITHOUT PERMISSION FROM UL***

23.2 Bonding conductor

23.2.1 Bonding shall be accomplished by a metal-to-metal contact of parts or by a separate bonding conductor as specified in 23.2.6.

23.2.2 A bonding conductor shall be copper, copper alloy, or another acceptable material.

23.2.3 Ferrous metal in the grounding path shall be protected against corrosion by enameling, galvanizing, plating, or other equivalent means.

Exception: Corrosion protection is not required to be provided at electrical connections.

23.2.4 A separate bonding conductor:

- a) Shall be protected from mechanical damage or located within the outer enclosure; and
- b) Shall not be secured by a removable fastener used for a purpose in addition to bonding, unless the bonding conductor is not likely to be omitted if the fastener is removed and replaced as intended.

A bonding conductor shall be in metal-to-metal contact with the parts to be bonded.

23.2.5 A splice shall not be employed in a bonding conductor.

23.2.6 A separate component-bonding conductor relied upon as the primary ground path shall:

- a) Not be smaller than any internal conductor supplying the part to be bonded; or
- b) Comply with the Bonding Conductor Test, Section 47.

24 Spacings

24.1 Spacings between live parts of opposite polarity, between live and dead metal parts, and between live parts and a metal enclosure, shall be as specified in Table 24.1 or Table 24.2, as appropriate. If a live part is not rigidly secured in position by a means other than friction between surfaces, or if a movable dead metal part is in proximity to an uninsulated live part, the construction shall be such that at least the minimum spacings will be maintained.

Exception No. 1: Spacings between traces on a printed-wiring board need not comply with Tables 24.1 and 24.2 if the printed-wiring board complies with the abnormal operation test in 39.8. See also 22.3. The requirements specified in 22.3 and 39.8 do not substitute for the minimum required spacings between the printed-wiring board foils and dead metal parts or the spacings between the primary and secondary foils of the printed-wiring board as specified in Table 24.1 or 24.2.

Exception No. 2: This requirement does not apply to a unit complying with the requirements in 24.5 – 24.9.

Table 24.1
Spacing in units having openings

Potential involved, volts rms (peak)	Minimum spacings, inch (mm)		
	Through air	Over surface	Shortest distance to metal enclosure
50 or less (70.7)	1/16 (1.6)	1/16 (1.6)	1/16 (1.6)
51 – 150 (70.8 – 212.1)	1/8 (3.2)	1/4 (6.4)	1/4 (6.4)
151 – 250 (212.2 – 353.5)	1/4 (6.4)	3/8 (9.5)	1/2 (12.7)
251 – 600 (353.6 – 848.5)	3/8 (9.5)	1/2 (12.7)	1/2 (12.7)

Table 24.2
Spacing in units without openings

Potential involved, volts rms (peak)	Minimum spacings, inch (mm)	
	Through air and over surface	Shortest distance to metal enclosure
50 or less (70.7)	1/16 (1.6)	1/16 (1.6)
51 – 150 (70.8 – 212.1)	1/16 (1.6)	1/4 (6.4)
151 – 250 (212.2 – 353.5)	3/16 (4.8)	1/4 (6.4)
251 – 600 (353.6 – 848.5)	1/4 (6.4)	1/2 (12.7)

24.2 For the purpose of determining working voltage in units employing nonlinear circuitry:

- a) When the dc value is used, the peak value of any superimposed ripple shall be included;
- b) Non-repetitive transients (due, for example, to atmospheric disturbances) shall be disregarded;
- c) The voltage of a Class 2 circuit is regarded as zero for determination of through air spacings. However, the voltage of a Class 2 circuit shall be taken into account for determination of over surface spacings;
- d) Ungrounded accessible conductive parts shall be assumed to be grounded;
- e) Where a transformer winding or other part is floating (not connected to a circuit which establishes its potential relative to earth), it shall be assumed to be grounded at the point by which the highest working voltage is obtained;
- f) For insulation between two transformer windings, the highest voltage between any two points in the two windings shall be used, taking into account external voltages to which the windings are able to be connected;
- g) For insulation between a transformer winding and another part, the highest voltage between any point on the winding and the other part shall be used; and
- h) Nominal values of mains supply voltage shall be used.

24.3 All uninsulated live parts connected to different circuits, including all secondary circuits, shall be spaced from one another as though they were parts of opposite polarity and shall be evaluated on the basis of the highest voltage involved.

24.4 At other than field-wiring terminals, spacings in a Class 2 secondary circuit from the transformer secondary winding on or beyond the energy-limiting component, as may be appropriate, are not specified between live parts of opposite polarity and between a live part and a dead metal part.

24.5 As an alternative to the spacing requirements of Table 24.1 or Table 24.2, as appropriate, the spacing requirements in the Standard for Insulation Coordination Including Clearances and Creepage Distances For Electrical Equipment, UL 840, may be used. The spacing requirements of UL 840 shall not be used for output wiring terminals and spacings to a dead metal enclosure.

24.6 It is anticipated that the level of pollution expected will be pollution degree 2. Hermetically sealed or encapsulated enclosures, or coated printed wiring boards in compliance with the Printed-Wiring Board Coating Performance Test specified in the Standard for Insulation Coordination Including Clearances and Creepage Distances For Electrical Equipment, UL 840, are considered pollution degree 1.

24.7 It is anticipated the equipment will be rated overvoltage category II and overvoltage category I as defined in the Standard for Insulation Coordination Including Clearances and Creepage Distances for Electrical Equipment, UL 840.

24.8 In order to apply Clearance B (controlled overvoltage) clearances, control of overvoltage shall be achieved by providing an overvoltage device or system as an integral part of the product.

24.9 All printed-wiring boards are considered to have a minimum comparative tracking index (CTI) of 100 without further investigation.

24.10 An insulating barrier or liner used to provide spacings shall be of material acceptable for the application and shall not be less than 0.028 inch (0.71 mm) thick.

Exception No. 1: A barrier or liner used in conjunction with not less than half the required spacing through air may be less than 0.028 inch (0.71 mm) thick, but not less than 0.012 inch (0.305 mm) thick if the barrier or liner is of acceptable insulating material that is:

- a) Resistant to moisture;*
- b) Of acceptable mechanical strength if exposed or otherwise likely to be subjected to mechanical damage;*
- c) Reliably held in place; and*
- d) Located so that it is not adversely affected by operation of the device – particularly arcing.*

Exception No. 2: A barrier or liner may be less than 0.028 inch thick but not less than 0.010 inch (0.25 mm) thick in the secondary circuit where the potential is not more than 50 volts if it is:

- a) Resistant to moisture;*
- b) Of acceptable mechanical strength if exposed or otherwise likely to be subjected to mechanical damage; and*
- c) Reliably held in place.*

**UL COPYRIGHTED MATERIAL –
NOT AUTHORIZED FOR FURTHER REPRODUCTION OR
DISTRIBUTION WITHOUT PERMISSION FROM UL**

24.11 Insulating material having a thickness less than that specified in 24.10 may be used if, upon investigation, it is found to be acceptable for the application, and has a dielectric breakdown strength of not less than 5000 volts in the thickness used for 24.10, or 2500 volts in the thickness used for Exception No. 1 to 24.10, as determined by the Tests on Insulating Materials, Section 40.

24.12 Units, which are marked "Double Insulated" or marked with the symbol for double insulation, shall be investigated to the Standard for Double Insulation Systems for Use in Electronic Equipment, UL 2097.

PERFORMANCE

25 General

25.1 The number of representative samples indicated in Table 25.1 shall be subjected to the tests described in Sections 26 – 47. Unless otherwise specified, all tests are to be conducted at the applicable voltage specified in Table 25.2. A power unit marked with an operating voltage range shall comply with the requirements while connected to a source of voltage adjusted to that value within the specified range which results in the most severe operating condition.

**Table 25.1
Tests**

Section	Test	Number of samples to be subjected to test
26	Leakage Current	1
27	Leakage Current and Dielectric Voltage Withstand after Humidity Exposure	1
28	Maximum Output Voltage	1
29	Maximum Input	1
30	Output Current and Power	1
31	Calibration of Overcurrent Protection Devices Test	1
32	Full-Load Output Current	1
33	Normal Temperature	1
34	Dielectric Voltage Withstand	1
35	Endurance	1
34 and 35	Repeat Dielectric Voltage Withstand	1
36	Overload on Primary Switches	1
37	Overload on Secondary Switches	1
38	Operation	1
39	Abnormal: Output Loading	1 ^a
	Transformer Burnout	1 ^b
	Reverse Polarity	1
	Switch Position	1
	Component Malfunction or Breakdown	1 ^c
40	Tests on Insulating Materials	d
41	Strain Relief	1
43	Direct Plug-In Unit Blade Secureness	1
44	Direct Plug-In Unit Input Contact Security	1
45	Output Connector Security	1
46	Abuse: Impact on Direct Plug-In Units	3
	Impact on Cord Connected Units	3
	Rod Pressure on Direct Plug-In Units	1
	Resistance to Crushing on Direct Plug-In Units	1

**UL COPYRIGHTED MATERIAL –
NOT AUTHORIZED FOR FURTHER REPRODUCTION OR
DISTRIBUTION WITHOUT PERMISSION FROM UL**

Table 25.1 Continued on Next Page

Table 25.1 Continued

Section	Test	Number of samples to be subjected to test
47	Bonding Conductor	1
–	Tests for Thermoplastic Enclosures	e
	Mold Stress Relief Distortion	1 ^e
	Strain Relief Test after Mold Stress Relief Distortion	1 ^e
<p>^a One sample is required for each loading condition noted in 39.2.</p> <p>^b Additional samples may be required if multiple secondary windings are present. One sample is required for each secondary winding.</p> <p>^c Additional samples may be required if multiple components are present. One sample is required for each component to be faulted.</p> <p>^d A sample representative of the insulating system material or materials is to be tested.</p> <p>^e Based on the Standard for Polymeric Materials – Use in Electrical Equipment Evaluations, UL 746C.</p>		

Table 25.2
Values of test voltage

Rated Voltage	Test Voltage
110 – 120	120
121 – 219	Rated voltage
220 – 240	240
241 – 250	Rated voltage

25.2 With respect to 25.1 and footnotes a, b, and c of Table 25.1, a sample may be used for more than one test, providing the previous test did not damage the sample.

25.3 For tests in which the unit is to be connected to a supply circuit, the branch circuit shall be protected by a branch-circuit protective device having a rating equal to the smallest rated receptacle to which the unit may be connected. For a unit permanently connected to the input supply, the branch-circuit protective device shall be 15 amperes.

25.4 The frequency of the supply circuit is to be the rated frequency of the unit. If the unit is rated for a range of frequencies, the Maximum Input Test, Section 29, Full Load Output Current Test, Section 32, Normal Temperature Test, Section 33, and Endurance Test on Overcurrent- and Overtemperature-Protective Devices, Section 35, shall be conducted at the lowest rated frequency, and all other tests are to be conducted at the highest rated frequency.

25.5 For all tests in which a direct plug-in unit is to be energized from a source of supply, the unit is to be operated from an outlet representing the following constructions:

- a) Duplex receptacle outlet with nonmetallic faceplate;
- b) Receptacle mounted on a nonmetallic outlet box, not more than 12 cubic inches (196.6 cm³) in volume; and
- c) Outlet box mounted in a vertical wall section approximately 3-1/2 inches (88.9 mm) thick with plywood or gypsum wallboard surfaces and loosely filled with fiberglass or equivalent thermal insulation.

**UL COPYRIGHTED MATERIAL –
NOT AUTHORIZED FOR FURTHER REPRODUCTION OR
DISTRIBUTION WITHOUT PERMISSION FROM UL**

25.6 The cheesecloth mentioned in this standard is to be bleached cheesecloth running 14 – 15 square yards per pound mass (approximately 26 – 28 square meters per kilogram mass) and having what is known in the trade as a “count of 32 by 28,” that is, for any square inch, 32 threads in one direction and 28 threads in the other direction (for any square centimeter, 13 threads in one direction and 11 in the other direction).

25.7 The tests described in Sections 29 – 33, 35, and 36 – 40 are to be conducted in an ambient air temperature within the range of 21 – 30°C (70 – 86°F).

Exception: The Normal Temperature Test, Section 33, with or without standard fuses, but without other forms of overcurrent or overtemperature protectors, may be conducted in an ambient air temperature within the range of 10 – 40°C (50 – 104°F).

25.8 For tests which specify rated load conditions, a sample is to be connected to the load specified in Table 25.3.

25.9 With reference to Table 25.3, if an output is rated in watts or volt-amperes, the rated output current is considered to be the quotient of the watt or volt-ampere rating and the voltage rating.

Table 25.3
Unit output loading

Table 25.3 revised October 11, 2013

Type of output current	Load for test
Alternating	Variable resistor adjusted to result in rated output current.
Rectified	Variable resistor in parallel with a 10,000 microfarad capacitor ^a adjusted to result in rated output current; or, for the temperature test, a load as noted in 25.10, 25.11, or 25.12 if a battery charger is intended for use with specific batteries.
^a A parallel capacitor is not required if, at rated output current through a resistive load: <ul style="list-style-type: none"> a) The form factor (V_{rms}/V_{avg}) does not exceed 1.05; and b) The crest factor (V_{pk}/V_{rms}) does not exceed 1.05, where: <ul style="list-style-type: none"> V_{rms} = the RMS output voltage V_{avg} = the average output voltage V_{pk} = the peak output voltage 	

25.10 If a battery charger is to be tested using a lead-acid battery or batteries as the load, each battery is to be discharged to 1.75 volts per cell – measured with the load connected – at a rate not to exceed the discharge rate assigned by the battery manufacturer, but in any case, the rate of the discharge is not to exceed one-sixth of the ampere-hour capacity of the battery.

25.11 If a battery charger is to be tested with a typical 1.2 Volt per cell nickel cadmium battery or batteries as the load, each battery is to be discharged to 0.9 volts per cell – measured with the load connected – at a rate not to exceed the discharge rate assigned by the battery manufacturer.

25.12 If a battery charger is to be tested with a battery or batteries other than those specified in 25.10 and 25.11, the battery is to be discharged at a rate not exceeding the battery manufacturers maximum recommended discharge rate to an appropriate discharge voltage.

***UL COPYRIGHTED MATERIAL –
NOT AUTHORIZED FOR FURTHER REPRODUCTION OR
DISTRIBUTION WITHOUT PERMISSION FROM UL***

No Text on This Page

***UL COPYRIGHTED MATERIAL –
NOT AUTHORIZED FOR FURTHER REPRODUCTION OR
DISTRIBUTION WITHOUT PERMISSION FROM UL***

26 Leakage Current Test

26.1 The leakage current of a unit, tested in accordance with 26.3 – 26.7, shall not be more than:

- a) 0.5 milliampere for a portable unit; or
- b) 0.75 milliampere for a stationary unit.

26.2 Leakage current refers to all currents, including capacitively coupled currents, that may be conveyed between exposed surfaces and ground or other exposed surfaces of a unit.

26.3 All exposed surfaces, including output terminals, are to be tested for leakage currents. The leakage currents from these surfaces are to be measured to the grounded supply conductor individually as well as collectively where simultaneously accessible, and from one surface to another where simultaneously accessible, except not from one output terminal to another. Parts are considered to be exposed surfaces unless guarded by an enclosure that complies with the requirements for Enclosures, Section 8.

26.4 If a surface other than metal is used for the enclosure or part of the enclosure, the leakage current is to be measured using a metal foil with an area of 10 by 20 centimeters (3.94 by 7.88 inches) in contact with the surface. Where the surface is less than 10 by 20 centimeters, the metal foil is to be the same size as the surface. The metal foil is not to remain in place long enough to affect the temperature of the unit.

26.5 The measurement circuit for leakage current is to be as illustrated in Figure 26.1. The meter actually used for a measurement need only indicate the same numerical value for a particular measurement as would the defined instrument. The meter used need not have all the attributes of the defined instrument. The measurement instrument is to be as follows:

- a) The meter is to have an input impedance of 1500 ohms resistive shunted by a capacitance of 0.15 microfarad.
- b) The meter is to indicate 1.11 times the average of the full-wave rectified composite waveform of voltage across the resistor or current through the resistor.
- c) Over a frequency range of 0 – 100 kilohertz, the measurement circuitry is to have a frequency response – ratio of indicated to actual value of current – equal to the ratio of the impedance of a 1500-ohm resistor shunted by a 0.15-microfarad capacitor to 1500 ohms. At an indication of 0.5 milliampere, the measurement is to have an error of not more than 5 percent.

Figure 26.1
Leakage-current measurement circuit

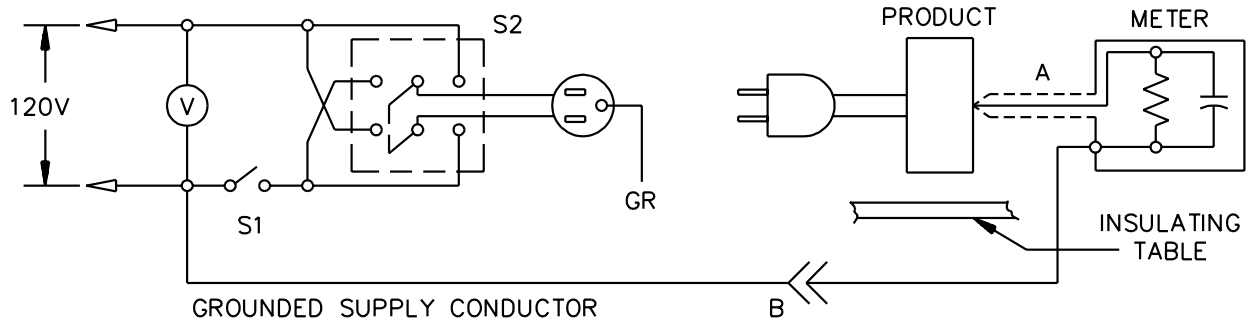

LC100

Unit intended for connection to a 120-volt supply.

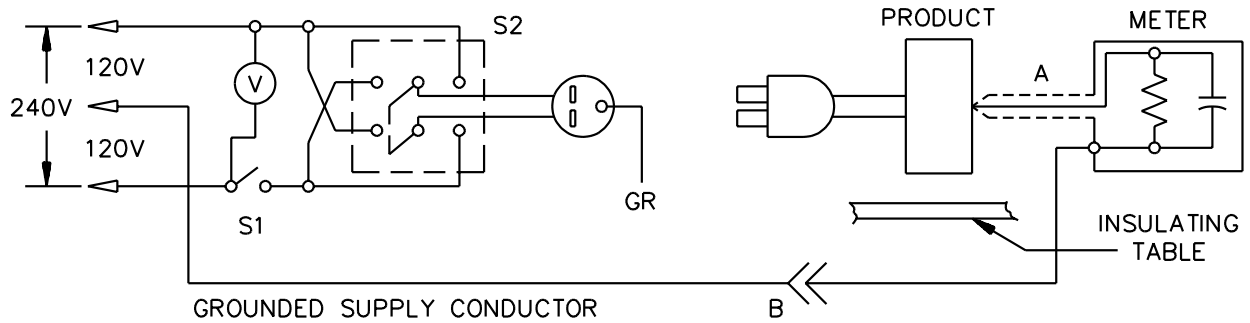

LC200

Unit intended for connection to a 3-wire, grounded neutral power supply, as illustrated above.

A. PROBE WITH SHIELDED LEAD.

B. SEPARATED AND USED AS CLIP WHEN MEASURING CURRENTS FROM ONE PART OF DEVICE TO ANOTHER.

**UL COPYRIGHTED MATERIAL –
NOT AUTHORIZED FOR FURTHER REPRODUCTION OR
DISTRIBUTION WITHOUT PERMISSION FROM UL**

26.6 Unless the meter is being used to measure leakage from one part of the unit to another, the meter is to be connected between the accessible parts and the grounded supply conductor.

26.7 A sample of the unit is to be tested for leakage current starting with the as-received condition (see 26.8) but with its grounding conductor open at the attachment plug. A resistance load is to be adjusted to draw the rated output of the unit in watts or volt-amperes at rated voltage. This load is to be connected to the output terminals prior to the start of the test sequence. The test sequence, with reference to the measurement circuit, Figure 26.1, is to be as follows:

- a) With switch S1 open, the unit is to be connected to the measurement circuit. Leakage current is to be measured using both positions of switch S2, and with the unit's switching devices in all their normal positions.
- b) Switch S1 is then to be closed, energizing the unit and the load on the output terminals, and within 5 seconds the leakage current is to be measured using both positions of switch S2 and with the unit switching devices in all their normal positions.
- c) Leakage current is to be monitored until ultimate results are obtained. Both positions of switch S2 are to be used in making this measurement. Ultimate results are considered to be attained by operation for 1 hour.

26.8 For the purpose of 26.7, the as-received condition is to be without prior energization except as may occur as part of the production line testing.

26.9 A sample is to be subjected to the complete leakage current test program as covered by 26.7 without interruption for other tests. The unit shall then comply with the Dielectric Voltage Withstand Test, Section 34.

27 Leakage Current Test and Dielectric Voltage Withstand Test After Humidity Exposure

27.1 A unit shall comply with the Leakage Current Test, Section 26, and Dielectric Voltage Withstand Test, Section 34, following exposure for 48 hours to air having a relative humidity of 88 ± 2 percent at a temperature of $32 \pm 2^\circ\text{C}$ ($89.6 \pm 3.6^\circ\text{F}$).

27.2 To determine whether a unit complies with the requirement in 27.1, a sample of the unit at a temperature just above 34°C (93.2°F) is to be conditioned for 48 hours in a humidity chamber maintained as specified in 27.1. Following the conditioning, the sample is to be tested unenergized as described in 26.7(a), and then energized and tested as described in 26.7(b) and 26.7(c). The test is to be discontinued when the leakage current stabilizes or decreases. The sample is then to be subjected to the Dielectric Voltage Withstand Test, Section 34.

28 Maximum Output Voltage Test

28.1 The maximum output voltage under any load condition (including no load) between any two output terminations of a unit shall not be more than the peak voltages specified in 16.2.2 when the primary is connected to the supply circuit. The Exception to 16.2.2 does not apply to this requirement. See 28.3.

28.2 If a unit has more than one pair of output terminations, the output voltage mentioned in 28.1 is to be measured with any combination of interconnections of the output terminations.

28.3 The maximum voltage between output terminations of a multiple output unit may exceed the values specified in 28.1 when the output terminations are interconnected, if the following conditions are met:

- a) The maximum output voltage between any two terminations is not more than the values indicated in 28.1 when no connections are made between the output terminations; and
- b) The unit is marked in accordance with 52.10.

29 Maximum Input Test

29.1 The primary input of a direct plug-in or cord-connected unit shall not be more than 660 watts when the unit is connected to the supply circuit with any condition of secondary load, including the short-circuiting of any combination of outputs.

29.2 To determine compliance with 29.1, one sample of the unit is to be connected to the load specified in Table 25.3, and the loads are to be adjusted to cause maximum input to the sample. The supply circuit is then to be de-energized and the sample is to be allowed to cool to room temperature. The supply circuit is then to be energized a second time and the input power measured within 15 seconds after application of voltage to the primary windings.

30 Output Current and Power Test

30.1 General

30.1.1 The maximum output current and output volt-amperes specified in 30.2 and 30.3 are to be determined using a current meter and a watt meter. A resistive load is to be adjusted to result in maximum reading of the meters. With no further adjustment of the load, the sample is to be de-energized and cooled to room temperature. The sample is then to be energized and maximum current and wattage measurements are to be taken at the time specified in 30.2.

Exception: An inherently limited or a not inherently limited Class 2 transformer that complies with the requirements in the Standard for Low Voltage Transformers – Part 1: General Requirements, UL 5085-1, and the Standard for Low Voltage Transformers – Part 3: Class 2 and Class 3 Transformers, UL 5085-3, is not required to be tested in accordance with 30.2 or 30.3.

30.2 Inherently limited

30.2.1 Under any condition of resistive loading – including short-circuit and interconnection of outputs when not prohibited by marking – the maximum output current shall not exceed the value specified in Table 30.1 and the maximum output volt-amperes shall not be more than 100 volt-amperes, except as indicated in 30.2.3 and 30.3.1, for the following conditions, as applicable:

- a) For a unit which employs a transformer with no form of protection, the measurement is to be made 60 seconds after the unit is connected to the source of supply.
- b) For a unit which employs a transformer and an energy limiting impedance or energy limiting circuit (a resistor, a PTC device, or similar circuitry) required for the purpose (See 5.8), the measurement is to be made five seconds after the unit is connected to the source of supply.
- c) For a unit which employs a transformer and either a thermal cutoff, a fuse, or both, all protection is to be defeated during the test and the measurement made 60 seconds after the unit is connected to the source of supply.
- d) For a unit that employs a transformer and a combination of a limiting impedance or circuit required for the purpose, and a protective device (such as a thermal cutoff, a fuse, or both), all protective devices are to be defeated and the measurement is to be made five seconds after the unit is connected to the source of supply.
- e) For a unit that employs a dc input, in accordance with 1.1, and a combination of a limiting impedance or circuit required for the purpose, and a protective device (i.e. thermal cutoff, fuse, or both), the protective device is to be defeated and the measurement is to be made five seconds after the unit is connected to the source of supply.

Table 30.1
Maximum output current for inherently limited units

Circuit voltage (V_{max}) ^{a,b} ac or dc Volts	Maximum nameplate ratings		Maximum output current (I_{max}) ^c , Amperes
	Volt-Amperes	Amperes	
0 – 20	$5.0 \times V_{max}$	5.0	8.0
Over 20 to 30	100	$100/V_{max}$	8.0
Over 30 to 60, dc only	100	$100/V_{max}$	$150/V_{max}$

^a V_{max} : Maximum output voltage regardless of load with rated input voltage applied.
^b Voltage ranges shown are for sinusoidal alternating current and continuous direct current. For nonsinusoidal alternating current, maximum voltage shall not be greater than 42.4 volts peak. For direct current interrupted at a rate of 10 – 200 hertz, maximum voltage shall not be greater than 24.8 volts.
^c I_{max} is maximum output current regardless of load.

30.2.2 If the value of current and power cannot be obtained due to operation of a protective device, damage to the transformer, or the like:

- a) The values are to be extrapolated, if feasible, from the values measured earlier in the time period; or
- b) A protective device may be shunted to obtain the required data.

**UL COPYRIGHTED MATERIAL –
NOT AUTHORIZED FOR FURTHER REPRODUCTION OR
DISTRIBUTION WITHOUT PERMISSION FROM UL**

30.2.3 The current between output terminations of a multi-output unit is not required to comply with 30.2.1 when output terminations are interconnected if the following conditions are met:

- a) The output current between any two terminations is not more than the limit specified in 30.2.1 when no connections are made between output terminations of separate outputs;
- b) The unit is marked in accordance with 52.10; and
- c) There is no emission of flame or molten metal from the unit enclosure and no other evidence of a risk of fire or electric shock.

30.3 Not inherently limited

30.3.1 When the unit includes means to automatically de-energize the output circuit (see 11.11), the values of the output current and volt-amperes specified in 30.2.1 shall not exceed those specified in Table 30.2.

30.3.2 To determine if a unit complies with the requirement in 30.3.1, the unit is to be allowed to deliver the test current to a resistance load, with the primary connected to a source of supply. The unit is to be draped with a double layer of cheesecloth conforming to the device outline. Charring, glowing, or flaming of the cheesecloth is unacceptable.

Table 30.2
Maximum output current and volt-amperes for not inherently limited units

Circuit voltage (V_{max}) ^{a,b} ac or dc, volts	Maximum nameplate ratings		Maximum output (I_{max}) ^c , amperes	Maximum output volt-amperes, (VA_{max}) ^d	Maximum overcurrent protection rating, amperes
	Volt-amperes	Amperes			
0 – 20	$5.0 \times V_{max}$	5.0	$1000/V_{max}$	250 ^e	5.0
Over 20 to 30	100	$100/V_{max}$	$1000/V_{max}$	250	$100/V_{max}$
Over 30 to 60, dc only	100	$100/V_{max}$	$1000/V_{max}$	250	$100/V_{max}$

^a V_{max} is the maximum output voltage regardless of load with rated input voltage applied.
^b Voltage ranges shown are for sinusoidal alternating current and continuous direct current. For nonsinusoidal alternating current, maximum voltage shall not be greater than 42.4 volts peak. For direct current interrupted at a rate of 10 – 200 hertz, maximum voltage shall not be greater than 24.8 volts.
^c I_{max} is maximum ampere output regardless of load after operation as specified in 30.2.1.
^d VA_{max} is maximum volt-ampere output regardless of load after operation as specified in 30.2.1.
^e Maximum volt-amperes is 350 if maximum circuit voltage is 15 or less.

31 Calibration of Overcurrent Protection Devices Test

31.1 A protective device provided as a part of a not inherently limited unit shall operate in not more than the time indicated in Table 31.1 when the unit is delivering the specified secondary current. There shall be no emission of flame or molten metal from the enclosure, and no evidence of a risk of fire or electric shock as described in 39.1.2. The unit shall withstand the dielectric voltage withstand test as specified in 34.1.1(a), applied between the primary winding and secondary windings, and between the primary and exposed dead metal parts.

Exception: This test need not be conducted if a suitably rated (see Table 30.2) and calibrated fuse is provided in the output circuit.

31.2 During the test, the grounding means is to be connected to ground through a 3-ampere nontime-delay fuse and the unit is to be draped with a double layer of cheesecloth conforming to the outline of the unit.

Table 31.1
Maximum acceptable time for protection device operation

Rated secondary potential, volts	Secondary test current, amperes	Maximum time for protective device to operate, minutes
20 or less	10 ^a	2
20 or less	6.75 ^b	60
Over 20 to 30	$200/V_{max}$ ^{a,c}	2
Over 20 to 30	$135/V_{max}$ ^{b,c}	60
Over 30 to 60, dc only	$200/V_{max}$ ^{a,c}	2
Over 30 to 60, dc only	$135/V_{max}$ ^{b,c}	60

^a The load is to be adjusted continuously to maintain the test current value shown.
^b After 15 minutes of operation, the load is to be readjusted to return the output current value shown.
^c V_{max} is the maximum output voltage regardless of load with rated input.

32 Full-Load Output Current Test

32.1 A unit shall deliver its rated full-load secondary current continuously.

Exception: The test of 32.2 is not required for a battery charger that is marked for a specific battery load per the Exception to 50.1 and is not marked with the output ratings.

32.2 To determine compliance with the requirement in 32.1, one sample is to be tested as follows. With a variable load as specified in Table 25.3 and an ammeter connected to the output, the primary is to be connected to the supply circuit. The load is to be adjusted to draw rated output current. After 15 minutes of operation, the resistance is to be readjusted, if necessary, to return the current to that value. The test is then to be continued for 1 hour without further adjustment. At the end of 1 hour, the output current shall not be less than 90 percent of the rated load current. An overtemperature- or overcurrent-protective device shall not function during this test.

32.3 If a unit has its output rated in volt-amperes or watts, the rated output current is to be determined by dividing the rated output voltage into the rated output volt-amperes or watts.

33 Normal Temperature Test

33.1 The temperature rises on various materials and parts shall not exceed the limits specified in Table 33.1 when the unit is operated as specified in 33.2 – 33.5. Upon completion of this test, the unit shall comply with the Dielectric Voltage Withstand Test, Section 34.

Table 33.1
Maximum acceptable temperature rises

Table 33.1 revised May 30, 2014

Materials and components		°C	(°F)
A.	COMPONENTS		
1.	Rubber- or thermoplastic-insulated conductors ^a	35	(63)
2.	Silicon components ^b	75	(135)
B.	ELECTRICAL INSULATION – GENERAL		
1.	Class 105 insulation systems:		
	Resistance method	75	(135)
	Thermocouple method	65	(117)
2.	Class 120 insulation systems:		
	Resistance method	85	(153)
	Thermocouple method	75	(135)
3.	Class 130 insulation systems:		
	Resistance method	95	(171)
	Thermocouple method	85	(153)
4.	Class 155 insulation systems:		
	Resistance method	115	(207)
	Thermocouple method	110	(198)
5.	Class 180 insulation systems:		
	Resistance method	135	(243)
	Thermocouple method	125	(225)
6.	Class 200 insulation systems:		
	Resistance method	150	(270)
	Thermocouple method	140	(252)
7.	Class 220 insulation systems:		
	Resistance method	165	(297)
	Thermocouple method	155	(279)
8.	Fiber employed as electrical insulation	65	(117)
9.	Phenolic composition ^a	125	(225)
10.	Varnish-cloth insulation	60	(108)
C.	SURFACES		
1.	Surface temperature, metal ^{c,d}	30	(54)
2.	Surface temperature, nonmetallic ^{c,e}	50	(90)
3.	Wood or similar material	65	(117)
^a The limitation on phenolic composition, rubber and thermoplastic insulation does not apply to compounds that have been investigated and found to be acceptable for use at a higher temperature. The maximum acceptable temperature rise in any case is 25°C (77°F) less than the acceptable temperature limit in question. ^b Does not apply to a material that has been investigated and found acceptable for a higher temperature.			

UL COPYRIGHTED MATERIAL –
NOT AUTHORIZED FOR FURTHER REPRODUCTION OR
DISTRIBUTION WITHOUT PERMISSION FROM UL

Table 33.1 Continued on Next Page

Table 33.1 Continued

Materials and components	°C	(°F)
<p>^c A material having a coefficient of thermal conductivity greater than 2.419 Btu per hour per square foot per foot per degree Fahrenheit (0.01 c/s/cm² /cm/°C) is considered to be metal. See 33.7.</p> <p>^d 45°C (81°F) rise for semipermanent mounted and permanently connected units marked as required by 52.5 and 70.2 respectively.</p> <p>^e 65°C (117°F) rise for semipermanent mounted and permanently connected units marked as required by 52.5 and 70.2 respectively.</p>		

33.2 For a direct plug-in unit, this test is to be conducted in both the horizontal and vertical positions. For a cord-connected unit, this test is to be conducted in all likely mounting positions. A sample is to be operated with the primary energized from a circuit as specified in 25.3 and 25.4. Each output is to be loaded as specified in 25.8. A battery charger which is likely to be used for consecutive charging of batteries is to be tested as specified in 33.5 and 33.6.

33.3 If the load mentioned in 33.2 and specified in 25.8 includes a variable resistance, the load is to be adjusted after 15 minutes of operation, if necessary, to return the output to the original value. If the load consists of a battery, the battery shall be discharged as specified in 25.10, 25.11, or 25.12, as applicable.

33.4 If a battery charger which is not likely to be used for consecutive charging of batteries is tested with a battery load, the test is to be continued until temperatures peak. The load is to be replaced by a second discharged battery. The test is terminated when temperatures peak during the second load condition.

33.5 A battery charger which is likely to be used for consecutive charging of batteries is to be tested with the intended battery load. The test is to be conducted in accordance with 33.6.

33.6 With respect to 33.5, a charger is to be tested in accordance with the following:

- a) For a charger with no charge status indicator, the test is to be continued until temperatures peak. The load is to be replaced with another discharged battery. This sequence is to be repeated until maximum temperatures are obtained.
- b) For a charger with a visual charge status indicator, the test is to be continued until the visual indicator indicates that the charge cycle is complete. The load is to be replaced with another discharged battery. This sequence is to be repeated until maximum temperatures are obtained.
- c) For a charger with a charge time marking or instruction, the test is to be continued until the specified charge time has elapsed. The load is to be replaced with another discharged battery. This sequence is to be repeated until maximum temperatures are obtained.
- d) For a charger with both a visual charge status indicator and a charge time marking or instruction, the test is to be continued until the specified charge time has elapsed or until the visual indicator indicates that the charge cycle is complete, whichever occurs first. The load is to be replaced with another discharged battery. This sequence is to be repeated until maximum temperatures are obtained.

33.7 With reference to footnote c to Table 33.1, the thermal conductivity of a material can be obtained by comparison with materials that have known thermal conductivities. Samples of materials with known values of the constant and a sample of the material for which the value is unknown are to be fixed to a heated metal plate. All samples are to be of the size used in the unit. The temperatures of the faces of the reference samples opposite the heated metal plate are to be plotted as a function of the constant. The constant of the material for which the value is unknown is derived from the curve by reading off the value corresponding to the temperature attained by the sample under investigation.

33.8 All values in Table 33.1 are based on an assumed ambient temperature of 25°C (77°F), but a test may be conducted at any ambient temperature within the range specified in 25.7.

33.9 A temperature is considered to be constant when three successive readings taken at intervals of 10 percent of the previously elapsed duration of the test, but not less than 15 minutes, indicate no further increase.

33.10 Except when it is specifically stated that the temperature determinations are to be made by the resistance method, temperatures are to be measured by means of thermocouples. The junction of the thermocouple is to be secured in intimate contact with the point of the surface at which the temperature is to be measured.

33.11 Thermocouples are to consist of wires not larger than 24 AWG (0.21 mm²) and not smaller than 30 AWG (0.05 mm²). When thermocouples are used in determining temperatures in electrical equipment, it is common practice to employ thermocouples consisting of 30 AWG iron and constantan wire and a potentiometer-type instrument; and such equipment is to be used whenever referee temperature measurements by thermocouples are necessary. The thermocouples and related instruments are to be accurate and calibrated in accordance with accepted laboratory practice. The thermocouple wire is to comply with the requirements listed in the Tolerances on Initial Values of EMF versus Temperature tables in the Standard Specification and Temperature-Electromotive Force (emf) Tables for Standardized Thermocouples, ANSI/ASTM E230/E230M.

33.12 Coil and winding temperatures are to be measured by thermocouples located on exposed surfaces, except the resistance method is to be used for a coil that is inaccessible for mounting of these devices such as a coil:

- a) Immersed in sealing compound;
- b) Wrapped with thermal insulation; or
- c) Wrapped with a material, such as cotton, paper, or rayon more than 1/32 inch (0.8 mm) thick.

33.13 The temperature rise of a copper winding is determined by the resistance method by comparing the resistance of the winding at a temperature to be determined with the resistance at a known temperature according to the formula:

$$\Delta t = \frac{R}{r} (k + t_1) - (k + t_2)$$

in which:

Δt is the temperature rise;

R is the resistance of the coil at the end of the test in ohms (see 33.14);

r is the resistance of the coil at the beginning of the test in ohms;

k is 234.5 for copper;

t_1 is the room temperature in degrees C at the beginning of the tests; and

t_2 is the room temperature in degrees C at the end of the test.

The winding is to be at room temperature at the start of the test.

33.14 Because it is generally necessary to de-energize the winding before measuring R , the value of R at shutdown may be determined by taking several resistance measurements at short intervals, beginning as quickly as possible after the instant of shutdown. A curve of the resistance values against time may be plotted and extrapolated to give the value of R at shutdown. Instrumentation by which R can be measured while the coil is energized may be used.

33.15 For manufacturers who choose to declare an operating ambient above 25°C, the following formulas can be used to determine compliance when testing in a normal room temperature environment:

$$\text{if } T_{\text{MAX}} \text{ is specified: } (T - T_{\text{AMB}}) \leq (T_{\text{MAX}} - T_{\text{MRA}})$$

$$\text{if } \Delta T \text{ is specified: } (T - T_{\text{AMB}}) \leq (\Delta T_{\text{MAX}} + 25 - T_{\text{MRA}})$$

where:

T = the temperature of the given part measured under prescribed test conditions; and

T_{MRA} = the maximum room ambient temperature permitted by the manufacturer's specification or 25°C, whichever is greater.

34 Dielectric Voltage Withstand Test

34.1 General

34.1.1 One minute after the applicable test, the unit shall withstand for 1 minute without breakdown the application of a potential. The test potential shall be:

- a) One thousand volts ac plus twice the maximum rated voltage between:
 - 1) The primary circuit and accessible dead metal parts; and
 - 2) The primary and secondary circuit or circuits.
- b) One thousand volts ac plus two times the sum of secondary voltages between secondary windings for units described in 28.3 or 30.2.3.
- c) Five hundred volts ac between a secondary circuit and dead metal parts.
- d) A dc potential of 1.414 times $(2 V + 1000)$, where V is the rms supply voltage, between the terminals of a capacitor used for radio-interference elimination or arc suppression.

Exception: If an ac potential results in excessive leakage through capacitors during the test specified in (a), (b), and (c), the capacitors are to be removed from the circuit for the ac potential. With the capacitors connected in the circuit, the unit shall withstand a dc potential of 1.414 times the ac rms potential between the points specified.

34.1.2 To determine if a unit complies with the requirements in 34.1.1, it is to be tested by means of a transformer of 500-volt-ampere capacity or larger, having an output voltage that is essentially sinusoidal or continuous direct current, as applicable, and can be varied. The applied potential is to be increased from zero until the required test level is reached, and is to be held at that level for 1 minute. The increase in applied potential is to be at a substantially uniform rate and as rapid as is consistent with its value being correctly indicated by a voltmeter.

Exception: A 500 volt-ampere or larger capacity transformer need not be used if the transformer is provided with a voltmeter to measure directly the applied output potential.

34.1.3 With respect to the electrical stress level mentioned in 12.2, each capacitor shall be subjected to a test potential as specified in 34.1.1(d).

34.2 Induced potential

34.2.1 One sample of a transformer as described in Exception No. 1 to 13.2.8 and 13.2.9 is to be subjected to this test. While in a heated condition from operation as described in Normal Temperature, Section 33, the primary winding shall withstand without breakdown an alternating potential of twice the rated voltage of the winding. The potential is to be:

- a) Applied for 7200 cycles if the frequency is 120 hertz or more; or
- b) 60 seconds if the frequency is less than 120 hertz.

A higher test frequency may be necessary so the core is not saturated.

34.2.2 The test voltage is to be started at one-quarter or less of the full value and increased to full value in not more than 15 seconds. After being held for the time specified, the voltage is to be reduced within 5 seconds to one-quarter or less of the maximum value and the circuit is to be opened.

34.2.3 With reference to 34.2.1, a transformer may be conditioned in an oven to obtain the temperature reached in the Normal Temperature Test, Section 33, before conducting the induced potential test.

35 Endurance Test on Overcurrent- and Overtemperature-Protective Devices

35.1 One sample of a unit employing a manually reset overcurrent- or overtemperature-protective device shall be operated under the condition of maximum obtainable output current, including short circuit, and the protector shall be cycled for 50 operations as quickly as the protector can be reset. During this test the grounding means, if provided, is to be connected to ground through a 3-ampere nontime delay fuse. A risk of fire or electric shock as described in 39.1.2 shall not result and the temperature rise at any point on the enclosure shall not exceed 65°C (117°F). The protector device shall be operational upon completion of the test.

35.2 One sample of a unit employing an automatically reset protective device or a protector that stays open as long as the overload is connected is to be connected and operated under the conditions described in 35.1 for 15 days but not less than 2000 cycles. A risk of fire or electric shock – see 39.1.2 – shall not result and the temperature rise at any point on the enclosure shall not exceed 65°C (117°F). Temperatures are to be measured at the end of the test. The protective device shall be operational upon completion of the test.

35.3 The test described in 35.2 shall be conducted for 24 hours for units incorporating thermostats, the acceptability of which has been determined by the requirements in the Standard for Temperature-Indicating and -Regulating Equipment, UL 873. Compliance with the Standard for Automatic Electrical Controls for Household and Similar Use, Part 1: General Requirements, UL 60730-1, and/or the applicable Part 2 standard from the UL 60730 series fulfills these requirements.

35.3 revised October 11, 2013

35.4 Following the endurance test, the unit is to be subjected to a repeat dielectric voltage withstand test as described in Section 34.

36 Overload and Endurance Tests on Switches and Controls

36.1 A switch or other control that has not been shown to be acceptable for the purpose in accordance with 10.6 shall perform acceptably when subjected to an overload test consisting of 50 cycles of operation making and breaking the applicable load, and to an endurance test consisting of 6000 cycles of operation at rated load. There shall be no electrical or mechanical breakdown of the device, undue burning or pitting of the contacts as a result of the overload or endurance test, or opening of the fuse in the grounding connection.

36.2 For the test specified in 36.1, the output of the unit is to be connected to its intended load based on its input and output ratings and to a supply having a frequency specified in 25.4. For the overload test, the supply voltage is to be increased to 110 percent of the maximum test voltage specified in 25.1. For the endurance test, the test voltage specified in 25.1 is to be used. During these tests, exposed dead metal parts of the unit are to be connected to ground through a 3-ampere nontime-delay fuse. The device is to be operated at a rate of not more than 10 cycles per minute, except that a faster rate of operation may be employed if agreeable to those concerned.

37 Overload Test on Secondary Switches

37.1 If tests are required in accordance with 10.7, a switch or other control device shall be tested as described in 37.2. The performance is unacceptable if:

- a) The fuse in the grounding connection opens during the test;
- b) There is welding of contacts or mechanism breakdown; or
- c) The device is otherwise incapable of completing the tests.

37.2 To determine if a secondary circuit switch or other control device is capable of performing acceptably in the overload test mentioned in 10.7, the unit is to be connected to a circuit supplying the maximum test voltage as specified in 25.1 and the rated frequency in accordance with 25.4. The switch is to be caused to make and break 150 percent of the rated secondary load current or maximum obtainable, whichever is less. During the test, exposed dead-metal parts of the unit are to be connected to the polarity opposite to the switching device through a 3-ampere fuse. The device is to be operated for 50 cycles at a rate of not more than 10 cycles per minute, except that a faster rate of operation may be employed if agreeable to those concerned.

38 Operation Test

38.1 A switch or other controller required to be tested in accordance with 10.8 is to be subjected to 1000 operations through all positions. The operations are to be with no electrical load. There shall be no mechanical breakdown of the switching mechanism or loosening of parts.

38.2 After the 1000 operations, the switch shall be capable of making and breaking the circuit for 50 cycles of operation as indicated in the Overload and Endurance Tests on Switches and Controls, Section 36. For a voltage selector switch, the test voltage is to be based on the highest rated voltage.

39 Abnormal Tests

39.1 General

39.1.1 A unit shall not emit flame or molten metal or become a risk of fire or electric shock when subjected to the following tests: output loading, reverse polarity, switch position, component breakdown, and when required, the printed wiring board abnormal operation test. Each abnormal test shall be followed by a dielectric voltage withstand test as required by 34.1.1(a).

39.1.2 A risk of fire or electric shock is considered to exist if any of the following occur:

- a) Opening of the grounding fuse;
- b) Charring of cheesecloth;
- c) Emission of flame or molten material from the unit enclosure and output cord, if provided;
- d) Any condition that exposes live parts which pose a risk of electric shock as specified in Accessibility of Live Parts, Section 16;
- e) Indication of dielectric breakdown;
- f) For a direct plug-in unit, loss of structural integrity to a degree where the unit cannot be removed from a receptacle immediately after the test without deformation or a risk of electric shock; or
- g) Opening of the branch-circuit overcurrent protective device.

39.1.3 Each test is to be conducted on a separate sample unless the manufacturer requests that more than one test be conducted on the same sample.

39.1.4 During each test, the grounding means, if provided, is to be connected to ground through a 3-ampere nontime-delay fuse.

39.1.5 A polarity-protection circuit provided to reduce the likelihood of output-current flow until a battery is connected as intended to the output is to be made inoperative so that the required output current will flow.

39.1.6 During all abnormal tests, the unit is to be draped with a double layer of cheesecloth conforming to the outline of the unit.

Exception: The cheesecloth is not required to be used during the short-circuit condition of the output loading test.

39.1.7 The temperature rises specified are based on an assumed ambient temperature of 25°C (77°F), but a test may be conducted at any ambient temperature of 21 – 30°C (70 – 86°F). However, if the operation of an automatic thermal control during the test limits the temperatures under observation, no temperature higher than 25°C (77°F) plus the specified maximum rise is acceptable.

39.2 Output loading

39.2.1 During the tests of 39.2.2 and 39.2.3, a fuse or circuit breaker provided as part of the unit is to remain in the circuit, and a user replaceable fuse is to be replaced by the largest fuse the fuseholder will accept. A manually reset protector is to be operated for 10 cycles and the protector contacts shall be operative upon completion of the test. If an automatic reset protector is provided, or the input current is a value other than zero, the test is to be continued for:

- a) 7 hours; or
- b) 15 days in accordance with 13.2.4.

For units with more than one output, the remaining outputs are to be open circuited or loaded to rated conditions in accordance with Table 25.2, whichever results in a more severe operating condition.

39.2.2 Each output is to be short-circuited in turn. The temperature rise on the enclosure of a direct plug-in unit shall not exceed 65°C (117°F).

Exception: A temperature rise of 125°C (225°F) is acceptable if the unit permanently opens within 1 hour after initiation of the test.

39.2.3 Each output is to be overloaded in turn. Each overload condition is to be conducted with the output loaded to a current (I_L) equal to the rated current (I_R) plus X percent of the difference between the maximum current (I_{max}) in accordance with Table 39.1 and the rated output current (I_R). In the tests, the values of X are to be 100, 75, 50, 25, 20, 15, 10, and 5, in that order. If a load current results in continuous operation, further tests need not be conducted. For each test, a variable resistance load is to be adjusted to the required value and readjusted, if necessary, one minute after application of the source of supply.

Exception: The alternate test method of 39.3 may be used for units that employ a:

- a) Thermal link complying with the Standard for Thermal-Links – Requirements and Application Guide, UL 60691; or
- b) Fuse complying with the Standard for Low-Voltage Fuses – Part 14: Supplemental Fuses, UL 248-14.

Table 39.1
Maximum current for output loading

Unit type	I_{max}
Inherently limited	As determined per 30.1.1
Not inherently limited	$200/V_{max}^a$
^a V_{max} per 28.1	

39.3 Output loading – alternate method

39.3.1 With reference to the Exception to 39.2.3, if the output short circuit test of 39.2.2 results in opening of a thermal link or fuse, the alternate method of 39.3.2 or 39.3.3 may be performed in lieu of 39.2.3.

39.3.2 If short circuiting causes opening of a thermal link, the device is to be shunted and a thermocouple attached to its body. The load current is to be raised slowly until a temperature equal to the rated trip temperature of the device plus 5°C (9°F) is reached. Without further readjustment of the load, the unit is to be operated for the remainder of the specified time length (7 hours or 15 days, as applicable).

39.3.3 If short circuiting causes opening of a fuse, the unit is to be tested with a load current that causes the maximum current to flow in the fused circuit without opening the fuse. The maximum current to be delivered through the fuse is to be determined by the following formula:

$$I_{FC} = 1.1 (I_{FR}) [1 + n(0.02)]$$

in which:

I_{FC} is the fuse overload current;

I_{FR} is the fuse current rating; and

n is an integer that causes the unit to run such that I_{FC} is able to be maintained at its continuous maximum current (7 hours or 15 days, as applicable).

When conducting this test, at least two load conditions are to be used; one load condition where I_{FC} ($n=c$) results in continuous operation, and one load condition where I_{FC} ($n=c+1$) results in opening of the fuse prior to the specified time length (7 hours or 15 days, as applicable). Prior to each test, the sample is to be at room temperature.

39.4 Transformer burnout

39.4.1 A unit having components in the output circuit shall not emit flame or molten metal or result in a risk of fire or electric shock as described in 39.1.2 while first operating as described in the temperature test, followed by operation under the loading conditions described in 39.4.3 for linear designs, 39.4.4 for switch mode designs. Each test is to be followed by a dielectric voltage withstand test described in 34.1.1(a) with the potential applied between primary and secondary windings. During this test the grounding means, if provided, is to be connected directly to ground. The unit is to be operated continuously:

- a) Until ultimate conditions are observed, including opening of a thermal cutoff or a similar device;
- b) For 7 hours if temperatures stabilize or cycling of an automatically reset protector occurs; or
- c) For 50 cycles of resetting a manually reset protector.

39.4.2 If a transformer has more than one secondary winding or a tapped secondary winding, separate tests are to be conducted for each winding, or each section of a tapped winding, with the other windings loaded or unloaded as may occur in service unless it can be determined that one condition will produce the most unfavorable results.

39.4.3 For linear designs, a resistive load that will draw three times the normal input alternating current or maximum obtainable output current, whichever is less, is to be connected directly to the transformer secondary winding with the unit connected to the maximum test voltage.

39.4.4 For switch mode designs, a resistive load is to be connected at a point in the secondary circuit where energy limiting circuitry (see 5.8) is not affected. The load is to be adjusted to result in three times the normal input current to the transformer or maximum obtainable output current, whichever is less.

39.5 Reverse polarity

39.5.1 For a device intended for charging batteries and provided with nonpolarized output connections, the external output leads are to be connected in reverse polarity to a fully charged battery intended for the application. The unit is then to be connected to its maximum test voltage, and operated until the ultimate condition is observed, or 4 hours if cycling of an automatically reset protector occurs.

39.6 Switch position

39.6.1 In accordance with 14.1.4, 14.2.3, and 14.2.4, a unit employing a primary-voltage selector switch shall be connected to the maximum test voltage and to its rated normal load. The switch is then to be adjusted to the lowest voltage position. Operation of the unit is to continue:

- a) Until ultimate conditions are observed;
- b) For 7 hours, if cycling of an automatically reset protector occurs; or
- c) For 10 cycles of resetting a manually reset protector.

39.7 Component breakdown

39.7.1 When tested in accordance with 39.7.2, a unit having components – such as diodes, resistors, transistors, capacitors, and the like – with a single component fault of short or open, shall not result in:

- a) The output capacity exceeding Class 2 characteristics; and
- b) Any condition as specified in 39.1.2.

Exception No. 1: This test need not be conducted for component breakdowns that result in open or short circuiting of the output, in short circuiting of the transformer, or for a component in a Class 2 circuit. See the transformer burnout test specified in 39.4.

Exception No. 2: This test need not be conducted if the components have been investigated and found to have permanence and stability so as to not decrease their limiting capabilities. See 12.1. For the purpose of this test, capacitors connected across the output are not considered likely to open.

39.7.2 A unit as identified in 39.7.1 is to be connected to the maximum test voltage and operated until ultimate conditions are observed, or for 4 hours if cycling of an automatically reset protector occurs.

39.8 Printed-wiring board abnormal operation test

39.8.1 To comply with Exception No. 1 to 24.1, a printed-wiring board is to be tested as described in 39.8.2 – 39.8.5.

39.8.2 During this test, if a printed-wiring board trace opens, the gap is to be electrically shorted and the test continued until ultimate results occur. This applies to each occurrence. If the circuit is interrupted by the opening of a component other than described in 39.8.3, the test is to be repeated two more times using new components as necessary.

39.8.3 Operation of an overcurrent protective device other than the branch circuit overcurrent protective device is acceptable.

39.8.4 A sample of the unit employing the printed-wiring board is to be connected to its nominal rated supply circuit as specified in Section 25, General. A foil trace is to be short-circuited to each of its adjacent traces that do not have the spacing specified in Table 24.1 or 24.2 one at a time.

39.8.5 The test is to be continued for 1 hour or until one of the conditions described in 39.1.2 occurs. However, if at the end of 1 hour no condition described in 39.1.2 occurs, but indications are that such a condition may eventually occur, the test is to be continued until ultimate results are obtained (usually 7 hours).

39.9 Backfeed protection

39.9.1 The output connector of a battery charger provided with backfeed protection in accordance with 15.4.3 (b) or (c) shall be subjected to the test described in 39.9.2. As a result of the test, the backfeed current shall not exceed 8.0 amperes at five seconds, and there shall be no emission of flame or molten material from the enclosure or output cord.

39.9.2 In accordance with 39.9.1, the output connector is to be connected to a source as specified in (a) or (b). A resistive load up to and including short circuit is to be connected as close as practicable across the output connector such that the maximum obtainable backfeed current is passed through the output connector. The current is to be measured at five seconds. The test is to be continued until ultimate results are obtained. The source shall be either:

- a) A fully charged battery of the size, type, and number specified by the manufacturer; or
- b) A dc source with a no load voltage rating equal to the output voltage rating of the battery charger and a nominal short-circuit capacity of 200 amperes.

39.9.3 A battery charger provided with backfeed protection in accordance with 15.4.3(d) shall be subjected to simulated component faults, one at a time, of open or short circuit which may result in backfeed of current into the secondary circuit (refer to 39.9.4). During the test the output connector shall be connected to a source as specified in 39.9.2 (a) or (b), and the test is to be continued until ultimate results are obtained. One minute after the test the unit shall be subjected to the dielectric voltage withstand test of 34.1.1 (a), (b) and (c). As a result of the test, there shall be no emission of flame or molten material from the enclosure or output cord, and no indication of dielectric breakdown.

39.9.4 In accordance with 39.9.3, faults shall be simulated for components such as diodes, transistors, capacitors, and the like unless the components have permanence and reliability (see 12.1). If an overcurrent protector, such as a fuse or PTC, operates to limit the backfeed current, the protector shall comply with requirements applicable to the component.

40 Tests on Insulating Materials

40.1 If required by 13.2.1(b), 13.2.2(c), 13.2.5(c), 13.2.6(c), 13.2.10(b), insulating material shall be subjected to the test described in 40.2.

Exception: The insulating material need not be subjected to this test if it is generic material noted in 40.3 and Table 40.1.

40.2 The insulating material is to be placed between two opposing electrodes. The electrodes are to be cylindrical brass or stainless steel rods 1/4 inch (6.4 mm) in diameter, with edges rounded to a 1/32-inch (0.8 mm) radius. The upper moveable electrode is to weigh 50 ± 2 grams to exert sufficient pressure on the specimen to provide good electrical contact. The test potential is to be increased to the test value and the maximum test potential is to be maintained for 1 second. The result is acceptable if there is no dielectric breakdown.

40.3 With reference to the Exception to 40.1, insulation may be of a generic material type specified in Table 40.1 where the layer(s) of each generic material is of a minimum thickness such that all layers collectively are greater than or equal to the minimum thickness required (T):

$$T \leq A_1 (EF_1) \pm A_2 (EF_2) \pm A_3 (EF_3) \dots$$

in which:

A₁, A₂, and A₃ denote the total thickness of each generic material type;

EF₁, EF₂, and EF₃ denote the equivalency factor specified in Table 40.1 for the generic material type corresponding to A₁, A₂, A₃; and

T is the thickness requirement for electrical grade paper.

Table 40.1
Equivalency factors for insulation materials^a

Generic material	Equivalency Factor (EF)
Electrical grade paper, fiber, or pressboard	1
Impregnated rag paper	1.3
Acetate sheet	1.5
Polyvinyl chloride (PVC)	1.3
Silicone rubber (SIR)	0.5
Impregnated glass or acetate cloth	1.2
Polyester	2
Polyethylene terephthalate (PETP)	2
Fluorinated ethylene propylene (FEP)	3
Polytetrafluoroethylene (PTFE)	3
Aramid paper	2
Polyamide (PI)	6
Mica ^b	4.7
^a See 40.3.	
^b EF applies if not subject to mechanical damage.	

**UL COPYRIGHTED MATERIAL –
NOT AUTHORIZED FOR FURTHER REPRODUCTION OR
DISTRIBUTION WITHOUT PERMISSION FROM UL**

41 Strain Relief Test

41.1 With internal connections disconnected, the strain relief means provided for a supply cord, or a multi-conductor output cord where the interconnection of outputs exceeds Class 2 shall withstand the force described in 41.3 applied to the cord for 1 minute without displacement or breakage of the cord or deformation of its anchoring surface.

41.2 The output wiring of a unit other than one having a multi-conductor cord as specified in 41.1 shall withstand the force described in 41.4 applied for 1 minute. The results are considered acceptable if, with the output wiring connected internally, movement of the cord does not result in:

- a) A reduction of spacings to primary or dead metal parts;
- b) Damage to the transformer or enclosure; or
- c) Interruption of the output wiring.

41.3 A 35 lbf (156 N) force is to be suspended from the cord and supported by the unit so that the strain relief means is stressed from the most severe angle that the construction of the unit permits.

41.4 For units employing a flexible output cord, or a multi-conductor cord where the interconnection of outputs does not exceed Class 2, a 20 pounds-force (89 N) is to be applied to the cord and supported by the unit so that the strain relief means is stressed from the most severe angle that the construction of the unit permits. For units employing output wiring consisting of separate leads, a 10 pounds-force (44 N) is to be applied to each lead.

42 Push-Back Relief Test

42.1 To determine compliance with 18.2, a product shall be tested in accordance with 42.2 without occurrence of any of the conditions specified in or 18.2 (a) – (d).

42.2 The supply cord or lead is to be held 1 inch (25.4 mm) from the point where the cord or lead emerges from the product and is then to be pushed back into the product. When a removable bushing which extends further than 1 inch is present, it is to be removed prior to the test. When the bushing is an integral part of the cord, the test is to be carried out by holding the bushing. The cord or lead is to be pushed back into the product in 1-inch (25.4-mm) increments until the cord buckles or the force to push the cord into the product exceed 6 pounds-force (26.7 N). The supply cord or lead within the product is to be manipulated to determine compliance with 18.2.

43 Direct Plug-In Blade Secureness Test

43.1 Each blade and the grounding pin, if provided, shall withstand a direct pull of 20 pounds-force (89 N) for 2 minutes without loosening. The two blades tested together shall also withstand a direct pull of 20 pounds for 2 minutes without loosening.

43.2 To determine whether a unit complies with the requirement in 43.1, it is to be supported on a horizontal steel plate with the blades projecting downward through a hole having a diameter sufficient only to permit the blades to pass through it. A 20-pound (9.1-kg) weight is to be supported by each blade and the grounding pin, if provided, in succession and then by the two blades tested together. In a unit of nonrigid construction – for example, a unit of soft molded material – the displacement of either blade shall not exceed 3/32 inch (2.4 mm) measured 2 minutes after removal of the weight.

44 Direct Plug-In Security of Input Contacts Test

44.1 General

44.1.1 The plug-in blades and the grounding pin shall not loosen to a degree that introduces a risk of fire or electric shock as a result of the tests described in 44.1.2 and 44.1.3.

44.1.2 A unit is to be rigidly supported in the blades-up position. Each blade, in turn, is to be individually subjected to a force of 30 pounds-force (133 N) applied gradually along the longitudinal axis of the blade in a direction towards the face of the unit. The 30 pounds-force is to be maintained for 1 minute.

44.1.3 The sample used in 44.1.2 is to be retested by being positioned as described in 44.1.2 and subjecting both blades and the grounding pin, if provided, in combination, to a single applied force of 40 pounds-force (178 N) for 1 minute.

44.2 Removable, folding, and retractable blade units

44.2.1 In addition to the requirements of 44.1, units employing removable, folding, or retractable blades for the input contacts shall be subjected to the testing indicated in 44.2.2 – 44.2.5.

44.2.2 The folding or retractable blades of the unit shall withstand 6000 cycles of rotating the blades from the plug-in position to the fully recessed position. For the purpose of this test, the blade is considered to be in the plug-in position when the actuator is extended, and the blades are in the “out” position and locked in place, as in normal use. The fully retracted position is considered to be when the actuator is retracted and the blades are returned to the “in” position.

44.2.3 The removable blades of the unit shall withstand 6000 cycles of removal and attachment.

44.2.4 At the conclusion of the cycling test of 44.2.2 and 44.2.3:

- a) The unit shall be operational;
- b) The unit shall not have any exposed live parts which pose a risk of electric shock, as specified in Section 16, Accessibility of Live Parts;
- c) There shall not be a loss of structural integrity to a degree that the unit is able to be inserted only partially or the unit cannot be removed from a receptacle immediately after the test without deformation or risk of electric shock;

**UL COPYRIGHTED MATERIAL –
NOT AUTHORIZED FOR FURTHER REPRODUCTION OR
DISTRIBUTION WITHOUT PERMISSION FROM UL**

- d) The unit is to comply with the Direct Plug-in Blade Secureness Test, Section 43, and the requirements in 44.1.1 – 44.1.3; and
- e) The blade connections internal to the unit shall not develop a high impedance, as determined by the test of 44.2.5.

44.2.5 In order to determine compliance with the requirement specified in 44.2.4(e), the unit is to be subjected to a temperature test in accordance with Section 33, Normal Temperature Test. The temperature test is to be performed both before and after the cycling described in 44.2.2 and 44.2.3. Particular attention is to be paid to the temperatures between the blades and the point of contact for the blades to determine if the electrical or mechanical integrity of the unit has been altered during the course of the cycling.

45 Security of Output Connectors Test

45.1 For a unit provided with wire-binding terminals as output connectors, a terminal or terminal stud shall not turn or cause stress on internal connections when subjected to the test of 45.2.

Exception: This requirement does not apply to a terminal plate for a wire binding screw, a wire binding screw, or a stud where:

- a) *Dislocation does not result in a reduction of spacings to parts which pose a risk of electric shock; and*
- b) *There is no likelihood of deformation to the extent that live parts which pose a risk of electric shock become accessible as determined by Accessibility of Live Parts, Section 16.*

45.2 The appropriate torque specified in Table 45.1 is to be applied for 10 seconds to the terminals in a direction tending to tighten them. The terminals are then to be loosened fully.

Table 45.1
Tightening torque for wire-binding screws

Size of terminal screw, number	Wire sizes to be tested		Tightening torque	
	AWG	(mm ²)	pound-inches	(N·m)
6	16 – 22	(1.3 – 0.32) ^a	12	(1.4)
8	14 and 16 – 22	(2.1) ^b and (1.3 – 0.32) ^a	16	(1.8)
10	10 – 14 or 16 – 22	(5.3 – 2.1) ^b or (1.3 – 0.32) ^a	20	(2.3)
^a Stranded wire. ^b Solid wire.				

45.3 Connection and disconnection of accessories shall not result in loosening of the connectors from a unit.

45.4 To determine compliance with 45.3, accessories are to be attached and detached from the unit 100 times and the connectors examined.

46 Abuse Tests

46.1 General

46.1.1 The enclosure of a unit shall withstand the applicable mechanical abuse tests described in 46.2 – 46.5 without:

- a) Making live parts which pose a risk of electric shock accessible to the probe illustrated in Figure 16.2; or
- b) Producing any other condition that results in a risk of electric shock.

46.1.2 The probe illustrated in Figure 16.2 applied as specified in 16.2.3 is to be used to determine whether a live part is accessible.

46.2 Impact on direct plug-in units

46.2.1 Three samples are to be subjected to this test. Each unit is to be dropped (free fall) three times in succession from a height of 3 feet (914 mm) onto a hardwood surface as described in 46.2.2. Each of the drops is to result in the impact occurring at a point on the unit different from the impact points on the other drops. The blades shall not be subjected to a direct impact.

Exception: If the manufacturer so elects, fewer samples may be used in accordance with Figure 46.1, wherein each series consists of three drops of the sample. The overall performance is acceptable upon completion of any one of the procedures represented in the figure.

Figure 46.1
Procedure for impact test

Series Number	Sample Number											
	1	2	3	1	2	3	1	2	3	1	2	3
1	↓ A	N	N	↓ A	N	N	↓ A	N	N	↓ A	N	N
2	↓ A	N	N	↓ A	N	N	↓ U	↓ A	N	↓ U	↓ A	N
3	↓ A	N	N	↓ U	↓ A	N	↓ A	N		↓ U	↓ A	

Arrows indicate sequence of test procedure

A – Acceptable results from drop

U – Unacceptable results from drop

N – No test necessary

SA1162

46.2.2 The hardwood surface mentioned in 46.2.1 is to consist of a layer of nominal 1-inch (25 mm) thick tongue-and-groove oak flooring [actual size 3/4 by 2-1/4 inch (19 by 57 mm)] mounted on two layers of nominal 3/4-inch (19-mm) thick plywood. The assembly is to rest on a concrete floor or an equivalent nonresilient floor during the test.

46.2.3 After completion of the drop test specified in 46.2.1, each sample is to be subjected to the Dielectric Voltage Withstand Test, Section 34, and to an examination for evidence of development of a risk of fire or electric shock.

46.3 Impact on cord connected units

46.3.1 Each of three samples is to be subjected to a single impact of 5 foot-pounds (6.78 N-m) on any surface that is exposed to a blow during intended use. This impact is to be produced by dropping a steel sphere, 2 inches (51 mm) in diameter and weighing approximately 1.18 pounds (535 g), from a height of 51 inches (1.30 m). The steel sphere is to strike the surface in a location different from those in the other two impacts. For surfaces other than the top of an enclosure, the steel sphere is to be suspended by a cord and allowed to swing as a pendulum dropping through a vertical distance of 51 inches (1.30 m).

Exception: The test of 46.3.1 may be performed on one sample impacted three times, in different locations.

46.3.2 If necessary to determine whether a unit complies with the requirements in 46.1.1 following the impact test described in 46.3.1, the dielectric voltage withstand test required by 34.1.1 is to be applied between live parts and accessible parts.

46.4 Rod pressure on direct plug-in units

46.4.1 Any point on the product that is accessible to the rod described in 46.4.2 shall be subjected to a force of 20 pounds-force (89 N) for 1 minute.

46.4.2 The force specified in 46.4.1 is to be increased from 0 to 20 pounds-force (0 to 89 N) over a period of 5 seconds applied through the axis of a 1/2 inch (12.7 mm) diameter metal rod, having a flat contact end with the edge rounded to a radius of 1/32 inch (0.8 mm) to eliminate sharp edges. The force is then to be maintained at 20 pounds for 1 minute. The axis of the rod is to be perpendicular to the surface under test. During the test, the unit is to rest on a flat surface in any convenient position, and is to be energized. Shock current between the enclosure and earth, and between any parts of the enclosure between which such currents may exist, are to be monitored. The instrumentation used is to be that described in 26.5.

46.4.3 During the rod-pressure test specified in 46.4.1 and 46.4.2, the shock current shall not exceed 7.07 milliamperes peak when the voltage involved exceeds 42.4 volts peak. Following the rod pressure test, the unit is to be subjected to the Dielectric Voltage Withstand Test, Section 34, and to an examination for evidence of the development of a risk of electric shock.

46.5 Resistance to crushing on direct plug-in units

46.5.1 One sample of the unit shall withstand for 1 minute a steady crushing force of 75 pounds-force (334 N) applied at right angles to the mounting surfaces. The enclosure is to be tested between two parallel, flat, hardwood blocks, each not less than 1/2 inch (12.7 mm) thick. One block is to contain slots into which the blades of the device are to be fully inserted. The crushing force is to be applied gradually in a direction normal to the mounting surface.

47 Bonding Conductor Test

47.1 With respect to 23.2.6, a bonding conductor that is smaller than any internal conductor supplying the part to be bonded is acceptable if, using a separate sample for each test, neither the bonding conductor nor the connection opens when:

- a) Carrying a current of 40 amperes for 2 minutes; and
- b) A sample is subjected to a limited-short-circuit test using a test current of 200 amperes while connected in series with a nonrenewable fuse rated 20 amperes.

47.2 The test circuit described in 47.1(b) is to have a power factor of 0.9 – 1.0 and a closed-circuit-test voltage as specified in 25.1. The open-circuit voltage is to be 100 – 105 percent of the closed-circuit voltage.

MANUFACTURING AND PRODUCTION TESTS

48 Dielectric Voltage Withstand Test

48.1 Each unit shall withstand without electrical breakdown, as a routine production line test, the application of a potential at a frequency within the range of 40 to 70 hertz:

- a) Between the primary circuit, including connected components, and accessible dead metal parts that are likely to become energized;
- b) Between primary wiring and secondary wiring, including terminals; and
- c) For units having the spacings specified in Table 24.2, between the primary circuit and dead-metal parts including the core whether accessible or not.

48.2 The applied potential for the test shall be either:

- a) 1000 volts for 60 seconds; or
- b) 1200 volts for 1 second.

48.3 The unit may be in a heated or unheated condition for the test.

48.4 The test is to be conducted when the unit is complete and fully assembled. It is not intended that the unit be unwired, modified, or disassembled for the test.

Exception No. 1: Parts such as snap covers or friction-fit knobs that interfere with performance of the test need not be in place.

Exception No. 2: The test may be performed before final assembly of the unit if the test represents that for the completed unit.

48.5 If a unit employs a solid-state component that may be damaged by the dielectric potential, the test may be conducted before the component is electrically connected provided that a random sampling of each day's production is tested at the potential specified in 48.2. The circuitry may be rearranged for the purpose of the test to reduce the likelihood of solid state component damage while retaining representative dielectric stress of the circuit.

48.6 The test equipment shall include a transformer having an essentially sinusoidal output, a means of indicating the test potential, an audible or visual indicator of electrical breakdown, and either a manually reset device to restore the equipment after electrical breakdown or an automatic reject feature of any unacceptable unit.

48.7 If the output of the test-equipment transformer is less than 500 volt-amperes, the equipment shall include a voltmeter in the output circuit to directly indicate the test potential.

48.8 If the output of the test equipment transformer is 500 volt-amperes or larger, the test potential may be indicated:

- a) By a voltmeter in the primary circuit or in a tertiary-winding circuit;
- b) By a selector switch marked to indicate the test potential; or
- c) In the case of equipment having a single test-potential output, by a marking in a readily visible location to indicate the test potential. When marking is used without an indicating voltmeter, the equipment shall include a positive means, such as an indicator lamp, to indicate that the manually reset switch has been reset following a dielectric breakdown.

48.9 Test equipment, other than that described in 48.6 – 48.8, may be used if found to accomplish the intended factory control.

48.10 During the test, the primary switch is to be in the "on" position, both sides of the primary circuit of the unit are to be connected together and to one terminal of the test equipment, and the second test equipment terminal is to be connected to accessible dead metal.

Exception No. 1: A unit having resistive circuitry, high-impedance winding, and the like, not subject to excessive secondary-voltage build-up in case of electrical breakdown during the test may be tested:

- a) With a single-pole primary switch, if used, in the "off" position; or*
- b) With only one side of the primary circuit connected to the test equipment when the primary switch is in the "on" position or when a primary switch is not used.*

Exception No. 2: The primary switch is not required to be in the "on" position if the testing means applies full test potential between primary wiring and dead-metal parts with the switch not in the "on" position.

49 Grounding Continuity Test

49.1 Each unit that has a grounding pin connected to a dead metal part as described in 23.1.1 shall be tested, as a routine production-line test, to determine that electrical continuity exists between the grounding pin and accessible dead metal parts of the units that are likely to become energized.

Exception: Parts described in the Exception to 23.1.1 are not required to be tested.

49.2 Only a single test need be conducted if the accessible metal selected is conductively connected by design to all other accessible metal.

49.3 Any acceptable indicating device – an ohmmeter, battery-and-buzzer combination, or the like – may be used to determine whether a unit complies with the grounding continuity requirement in 49.1.

RATING

50 General

50.1 The electrical ratings of a unit shall include: primary or input voltage or input voltage range; primary or input frequency expressed in hertz, Hz, cycles-per-second, cps, cycles/second, or c/s; output in amperes, volt-amperes, or watts for each output; and output voltage for each output in alternating or direct current.

Exception: When a battery charger is configured for use as part of a specific system and the battery is evaluated as part of the system, or when the charger is marked for use with a specific battery pack, the output ratings are not required to be marked on the charger.

50.2 If a unit is marked with an input amperes, volt-amperes, or watts rating, the rating shall be at least 90 percent of the value which occurs under rated load conditions when temperatures stabilize.

50.3 The output rating of each output shall not exceed 30 volts rms or 60 volts dc.

50.4 The sum of the volt-ampere ratings of all outputs shall not be more than 100 volt-amperes.

Exception: The sum of the volt-ampere ratings of all outputs may be more than 100 VA provided each output rating is not more than 100 VA and each output rating is individually marked.

50.5 If a volt-ampere or wattage rating is accompanied by an ampere rating, it shall be congruous with the other ratings.

MARKING

51 General

51.1 A unit shall be legibly and permanently marked, where readily visible, with:

- a) The manufacturer's name, trade name, or trademark;
- b) The date or other dating period of manufacture not exceeding any three consecutive months;
- c) A distinctive catalog or model number, or the equivalent; and
- d) The electrical rating.

Exception: The date of manufacture may be abbreviated, in an accepted conventional code, or in a code affirmed by the manufacturer.

51.2 If a manufacturer produces or assembles a unit at more than one factory, each unit shall have a distinctive marking to identify it as the product of a particular factory.

51.3 The repetition time cycle of a date code shall not be less than 20 years. The date code shall not require reference to the manufacturer's records to determine when the unit was manufactured.

51.4 A unit shall be marked with one of the following terms, as applicable:

- a) "Class 2 Battery Charger";
- b) "Class 2 Transformer";
- c) "Class 2 Power Supply"; or
- d) "Class 2 Power Unit."

See 52.11. A power unit may additionally be marked for use with a specific end product or end product type if investigated for the intended application. See 1.4.

Exception: Other designations conveying the intent of the terms specified may be used.

51.5 A unit shall not be marked "charger," or the equivalent, unless it employs a rectifying component.

51.6 The polarity of a direct-current output shall be plainly marked, unless the unit is provided with a polarized termination.

51.7 A power unit not furnished with a detachable power supply cord as described in the Exceptions to 14.2.1 and 14.2.3 shall be marked adjacent to the appliance coupler to inform the user to see the instruction manual (see 54.3) for proper selection of the power supply cord.

Exception: The marking may be in the form of a tag, nonpermanent label, or product insert that is provided on or packaged with the unit so that the marking is visible at the time of installation.

51.8 In accordance with 14.1.4 and 14.2.4, a power unit intended for use by travelers shall be marked with any of the following or equivalent:

- a) "See instruction manual for use in countries other than the U.S.A."
- b) "See instructions for input voltage conversion." or
- c) "See instructions if the input plug does not fit the power outlet."

51.9 A battery charger with backfeed protection in accordance with 15.4.3 shall be marked "Backfeed Protection", "BFP", or the equivalent.

52 Cautionary and Warning Markings

52.1 The marking shall be prefixed by the signal word "CAUTION" or "WARNING" in letters not less than 1/8 inch (3.2 mm) high. The remaining letters shall not be less than 1/16 inch (1.6 mm) high.

52.1 revised July 25, 2012

52.2 The marking shall be located on:

- a) A part that cannot be removed without impairing the operation of the unit; or
- b) A tag complying with the requirements in 52.3, 53.2, and 53.3.

52.2 revised July 25, 2012

52.3 The marking may be provided on a permanent tag that is secured to the input or output cord of a unit. The tag shall be attached in such a way that it cannot be easily removed. The tag shall also be marked "Do not remove this tag," or the equivalent, in letters not less than 3/32 inch (2.4 mm) high.

52.3 revised July 25, 2012

52.4 A direct plug-in unit having a mounting tab for semipermanent mounting shall be marked – on the unit, a marking tag, or an instruction sheet packed with the unit – with the signal word of 52.1 and the following mounting instructions or the equivalent:

- a) "Risk of Electric Shock – Disconnect power to the receptacle before installing or removing the unit. When removing receptacle cover screw, cover may fall across plug pins or receptacle may become displaced";
- b) "Use only with duplex receptacle having center screw"; and
- c) "Secure unit in place by receptacle cover screw."

52.4 revised July 25, 2012

52.5 A direct plug-in unit intended to be semipermanently mounted that exceeds the surface temperature limits specified in Table 33.1 for either metallic or nonmetallic shall be legibly marked where readily visible after installation with the signal word of 52.1 and the following or the equivalent: "HOT SURFACES – Risk of Burns – Do not touch."

52.5 revised July 25, 2012

**UL COPYRIGHTED MATERIAL –
NOT AUTHORIZED FOR FURTHER REPRODUCTION OR
DISTRIBUTION WITHOUT PERMISSION FROM UL**

52.6 A unit shall be marked with the signal word of 52.1 and "Risk of Electric Shock" and the following or the equivalent: "Dry location use only" or "Do not expose to liquid, vapor, or rain."

52.6 revised July 25, 2012

52.7 A direct plug-in unit that resembles an attachment plug of a power supply cord shall be plainly marked with the signal word of 52.1 and the following or the equivalent: "Risk of Fire or Electric Shock. Do not replace this plug assembly."

52.7 revised July 25, 2012

52.8 A unit which employs fusing in both supply conductors shall be marked, where readily visible during servicing, with the signal word of 52.1 and the following or equivalent: "Risk of Electric Shock. Both sides of line are fused. Test before touching."

Exception: A unit not likely to be serviced need not employ this marking.

52.8 revised July 25, 2012

52.9 A unit intended to charge batteries shall be marked, where readily visible to the user, with the signal word of 52.1 followed by "Risk of Injury" or "Risk of Fire" and one of the following or equivalent:

- a) "Refer to the instruction manual for the size, type, and number of batteries to be charged."
- b) "Charge only [type] type rechargeable batteries."

The [type] shall be filled in with an appropriate descriptor to instruct the user of the battery to be charged. (For example: 12 volt NiCd, AAA size NiCd, C size NiMH, [manufacturer name] Model [battery pack part number])

52.9 revised July 25, 2012

52.10 With reference to 28.3 and 30.2.3, a multi-output unit shall be marked, where readily visible after installation, with the word "WARNING" and the following or equivalent: "Risk of Fire or Electric Shock. Do not interconnect output terminations."

52.10 revised July 25, 2012

52.11 A unit employing output field-wiring terminals shall be marked "CLASS 2 NOT WET, CLASS 3 WET" or the equivalent if the open circuit output voltage exceeds:

- a) 21.2 volts peak;
- b) 30 volts for continuous direct current; or
- c) 12.4 volts for DC interrupted at a rate of 10 to 200 Hz.

Exception: If a unit having an output specified by (a) or (b) is marked with the maximum obtainable output peak voltage, it need not comply with the requirement.

52.12 A unit, as described in 15.3.4, shall be marked with the signal word of 52.1 and the following or the equivalent: "Risk of Fire. Use only Type SPT-2 or heavier cord, minimum ___ AWG copper." The minimum acceptable size is 18 AWG (0.82 mm²). The marking is to be located adjacent to the terminals or connectors or on a tag attached to the unit.

52.12 revised July 25, 2012

**UL COPYRIGHTED MATERIAL –
NOT AUTHORIZED FOR FURTHER REPRODUCTION OR
DISTRIBUTION WITHOUT PERMISSION FROM UL**

53 Application of Labeling

53.1 Unless specifically excepted, markings required by this Standard shall be permanent. A permanent marking shall be molded, die-stamped, paint-stenciled; stamped or etched metal that is permanently secured; or indelibly stamped on a pressure-sensitive label secured by adhesive that complies with the Standard for Marking and Labeling Systems, UL 969. Ordinary usage, handling, storage, and the like of the unit are to be considered in determining whether a marking is permanent.

53.2 The tag mentioned in 52.3 shall be made of durable material that provides mechanical strength, such as cloth, plastic, or the equivalent, and shall be large enough to accommodate the required marking in a size that is legible – also see 53.3. The tag shall be either:

- a) A flat tag having a hole large enough to accommodate the cord, but neither so large nor so positioned that it can easily be torn from the cord. To prevent removal or tearing, the tag is not to have a slit from the cord hole; or
- b) A flag-type tag with an adhesive back wrapped tightly once around and adhering to the cord. The ends of the tag are to adhere to each other and are to project as a flag.

53.3 The markings on a tag shall be printed in contrasting colors on a background other than blue or yellow and shall be located on the projecting flag of a flag-type tag.

INSTRUCTIONS

54 Instruction Manual

54.1 Multiple-voltage cord-connected equipment shall be provided with instructions to:

- a) Indicate the type of detachable supply cord and attachment plug that is to be used for connection to the alternate voltage; and
- b) Inform the operator to set the voltage selector switch to the voltage to which the product will be connected. See 14.2.3.

54.2 Multiple voltage equipment intended for use with a detachable power supply cord shall be provided with instructions to indicate the type of detachable power supply cord that is to be used for connection to the alternate voltage in accordance with 14.2.3.

54.3 In accordance with the Exceptions to 14.2.1 and 14.2.3, the instructions for a power unit intended for use with a detachable power supply cord which is not provided with the unit shall contain complete details concerning proper selection of the power supply cord. The instructions shall specify selection of a cord complying with the requirements in 14.2.1.

Exception: For a power unit intended for use in a foreign country, the instructions shall specify the appropriate cord to be used (see Exception No. 4 to 14.2.1).

54.4 With reference to 14.1.4 and 14.2.4, the instructions for a power unit intended for use by travelers shall include (a) – (c) or the equivalent, as appropriate. The items shall be preceded by "IMPORTANT SAFETY INSTRUCTIONS – SAVE THESE INSTRUCTIONS" and "DANGER – TO REDUCE THE RISK OF FIRE OR ELECTRIC SHOCK, CAREFULLY FOLLOW THESE INSTRUCTIONS" in letters of 1/8 inch (3.18 mm) high or in a readily visible contrasting text.

- a) "Be sure voltage selector is in correct voltage position before plugging in." The instructions shall also specify the procedures to follow for changing the voltage selector.
- b) "For use in the U.S.A., the voltage selector switch must be placed in the 120 volt position. For use in countries other than the U.S.A., the voltage selector may need to be placed in other than the 120 volt position. Confirm the voltage available at each country location before using the product."
- c) "For connection to a supply not in the U.S.A., use an attachment plug adapter of the proper configuration for the power outlet, if needed." Or, "If the shape of the plug does not fit the power outlet, use an attachment plug adaptor of the proper configuration for the power outlet."

54.5 The operating orientation of a direct plug-in power unit shall be indicated in the instructions as follows: "This power unit is intended to be correctly orientated in a vertical or floor mount position," or equivalent wording.

Exception: The instruction is not required for a direct plug-in power unit weighing 1 pound (454 g) or less.

OUTDOOR USE

55 General

55.1 The requirements in 55 – 66 supplement or modify the general requirements in Sections 1 – 54. These requirements are for equipment installed in outdoor locations that are exposed to weather.

56 Enclosures

56.1 A product intended for outdoor use shall comply with the Rain Test in 64.3.

Exception: A type 3R, 3S, or 4X enclosure evaluated in accordance with the Standard for Enclosures for Electrical Equipment, Non-Environmental Considerations, UL 50, is not required to be subjected to the Rain Test.

56.2 A product that is for use in an outdoor location shall comply with 64.1 and 64.2, in addition to the Ultraviolet (UV) Light Test and Water Immersion Tests specified in the Standard for Polymeric Materials – Use in Electrical Equipment Evaluations, UL 746C.

56.3 A power unit, or similar component, that is for use in an outdoor location and is to be mounted within 1 foot of the ground, whether as a separate product or provided as a part of a product, shall comply with the Standing Water Immersion Test in 64.4. A power unit installed at a height greater than 1 foot from the ground shall be marked in accordance with 65.6.

Exception: This requirement does not apply to a direct plug-in product.

**UL COPYRIGHTED MATERIAL –
NOT AUTHORIZED FOR FURTHER REPRODUCTION OR
DISTRIBUTION WITHOUT PERMISSION FROM UL**

56.4 A gasket or similar sealing device used to comply with the Rain Test in 64.3 shall comply with Section 58, Gaskets.

56.5 A panel, or cover, in the outer enclosure of an appliance shall require the use of a tool for removal.

Exception: This requirement does not apply when the removal or opening of the panel, or cover, does not result in a risk of electric shock when the appliance is subjected to the Rain Test described in 64.3.

56.6 An enclosure of a unit intended for outdoor use shall be constructed to reduce the risk of electric shock due to weather exposure and shall prevent live parts, electrical components, or wiring (not identified for use while in contact with water) from becoming wet. A part identified for use while in contact with water includes flexible cords (whose marking ends with a "W"), liquid tight flexible metal conduit, outlet boxes marked for use in wet locations, and rigid conduit.

56.7 To determine compliance with 56.6, a complete assembly shall be subjected to the Rain Test in 64.3.

56.8 The supporting surface of a power unit shall be supported by means other than ground level.

Exception: This requirement does not apply to a thermoplastic enclosed unit that complies with the Standing Water Immersion Test of 64.4.

56.9 A direct plug-in unit shall fully engage into a standard receptacle that is weatherproof only when the receptacle is covered (attachment plug cap not inserted and receptacle cover closed).

Exception: This requirement does not apply to a direct plug-in unit marked in accordance with 65.4 and provided with instructions in accordance with 66.3.

57 Protection Against Corrosion

57.1 Metal shall be used in combinations that are galvanically compatible.

57.2 A hinge and other attachments shall be resistant to corrosion.

57.3 A decorative grille, or similar part, that is not required to form a part of the enclosure is not required to comply with 57.4 – 57.14.

57.4 A non-metallic enclosure shall be judged on the basis of the effect of exposure to ultraviolet light and water, in accordance with the Standard for Polymeric Materials – Use in Electrical Equipment Evaluations, UL 746C.

57.5 A metallic enclosure shall be protected against corrosion as specified in 57.6 – 57.14. These requirements do not contemplate corrosion that is caused by exposure to earth or other corrosive agents.

57.6 Copper, bronze, and brass containing no less than 80 percent copper, or stainless steel may be used without additional protection against corrosion. Sheet, extruded, cast aluminum, die-cast zinc, and other metals shall be of a grade or alloy known to be resistant to atmospheric corrosion, shall be subjected to appropriate tests, or shall be protected against corrosion.

**UL COPYRIGHTED MATERIAL –
NOT AUTHORIZED FOR FURTHER REPRODUCTION OR
DISTRIBUTION WITHOUT PERMISSION FROM UL**

57.7 An enclosure of cast iron or malleable iron at least 3.2 mm (1/8 inch) thick shall be protected against corrosion by:

- a) A coating of zinc, cadmium, or the equivalent, which is 0.0038 mm (0.00015 inch) thick on the outside surface, and a visible coating of such metal on the inside surface; or
- b) One coat of an organic finish of the epoxy or alkyd-resin type, or other outdoor paint on each surface.

57.8 Corrosion tests are required unless suitability of a paint can be determined by consideration of its composition.

57.9 An enclosure of sheet steel less than 3.20 mm (0.126 inch) thick if zinc-coated, or 3.12 mm (0.123 inch) thick if uncoated, shall be protected against corrosion by other metallic or non-metallic coatings that have been found to give equivalent protection as described in 57.12, or by one of the following means:

- a) Hot-dipped mill-galvanized sheet steel conforming with the coating Designation G90 in the Weight (Mass) of Coating Requirements table in the Standard Specification for Steel Sheet, Zinc-Coated (Galvanized) or Zinc-Iron Alloy-Coated (Galvannealed) by the Hot-Dip Process, ASTM A653, with not less than 40 percent of the zinc on any side, based on the minimum single-spot test requirement in this ASTM specification. The weight of the zinc coating may be determined by any acceptable method; however, in case of question, the weight of the coating shall be established in accordance with the Standard Test Method for Weight (Mass) of Coating on Iron or Steel Articles With Zinc or Zinc-Alloy Coatings, ASTM A90;
- b) A zinc coating, other than that provided on hot-dipped mill-galvanized sheet steel, uniformly applied to an average thickness of no less than 0.015 mm (0.00061 inch) on each surface with a minimum thickness of 0.014 mm (0.00054 inch). The thickness of the coating shall be established by the Metallic Coating-Thickness Test described in the Standard for Enclosures for Electrical Equipment, Non-Environmental Considerations, UL 50. An annealed coating shall also comply with 57.14;
- c) A zinc coating conforming with 57.10(a) or 57.10(b) with one coat of an organic finish of the epoxy or alkyd-resin type or other outdoor paint on each surface applied after forming. See 57.8;
- d) A cadmium coating no less than 0.025 mm (0.001 inch) thick on both surfaces. The thickness of coating shall be established in accordance with the metallic coating thickness test described in the Standard for Enclosures for Electrical Equipment, Non-Environmental Considerations, UL 50; or
- e) A cadmium coating no less than 0.019 mm (0.00075 inch) thick on both surfaces with one coat of outdoor paint on both surfaces; or no less than 0.013 mm (0.00051 inch) thick on both surfaces with two coats of outdoor paint on both surfaces. The thickness of the cadmium coating shall be established in accordance with the metallic coating-thickness test described in the Standard for Enclosures for Electrical Equipment, Non-Environmental Considerations, UL 50, and the paint shall be as specified in (c).

57.10 An enclosure of zinc-coated sheet steel 3.20 mm (0.126 inch) thick or thicker, or an enclosure of uncoated sheet steel 3.12 mm (0.123 inch) thick or thicker, shall be protected against corrosion by other metallic or non-metallic coatings that have been shown to give equivalent protection as described in 57.12 or by one of the following means:

- a) Hot-dipped mill-galvanized sheet steel conforming with the coating Designation G60 or A60 in the Weight (Mass) of Coating Requirements table in the Standard Specification for Steel Sheet, Zinc-Coated (Galvanized) or Zinc-Iron Alloy-Coated (Galvannealed) by the Hot-Dip Process, ASTM A653, with no less than 40 percent of the zinc on any side, based on the minimum single-spot test requirement in this ASTM specification. The weight of zinc coating may be determined by any acceptable method; however, in case of question, the weight of coating shall be established in accordance with the Standard Test Method for Weight (Mass) of Coating on Iron or Steel Articles with Zinc or Zinc-Alloy Coatings, ASTM A90;
- b) A zinc coating, other than that provided on hot-dipped mill-galvanized sheet steel, uniformly applied to an average thickness of no less than 0.010 mm (0.00041 inch) on each surface with a minimum thickness of 0.009 mm (0.00034 inch). The thickness of the coating shall be established by the Metallic Coating-Thickness Test described in the Standard for Enclosures for Electrical Equipment, Non-Environmental Considerations, UL 50;
- c) Two coats of an organic finish of the epoxy or alkyd resin type or other outdoor paint on each surface. See 57.8; or
- d) Any one of the means specified in 57.9.

57.11 An enclosure of zinc-coated sheet steel 1.42 mm (0.056 inch) thick and an enclosure of uncoated sheet steel 1.35 mm (0.053 inch) thick intended to be mounted within and protected from direct exposure to weather by the enclosure of other equipment shall comply with 57.10. Such an enclosure shall not be marked rainproof or raintight.

57.12 A finish utilizing paint, metallic finish, or the combination of the two, may be used if comparative tests with galvanized sheet steel – without annealing, wiping, or other surface treatment – conforming with 57.9(a) or 57.10(a) indicate the finish provides equivalent protection, or when found to provide equivalent protection in accordance with the Standard for Organic Coatings for Steel Enclosures for Outdoor Use Electrical Equipment, UL 1332. The suitability of such coating systems shall be judged by exposure to salt spray, moist carbon dioxide-sulfur dioxide-air mixtures, moist hydrogen sulfide-air mixtures, ultraviolet light and water.

57.13 If tests are required, a test specimen of a finish as described in 57.7, 57.9(c), 57.10(c), and 57.12 shall be consistent with the finish that is used in production with respect to the base metal, cleaning or pretreatment method, application method, number of coats, curing method, and thickness.

57.14 A hot-dipped mill-galvanized A60 (alloyed) coating or an annealed zinc coating that is bent, or similarly formed, after annealing and that is not otherwise required to be painted shall be painted in the bent or formed area if the bending, or forming process, has damaged the zinc coating. The zinc coating is considered to be damaged if flaking or cracking of the zinc coating at the outside of the bent or formed section is visible at 25 power magnification. Simple sheared, cut edges, and punched holes are not considered to be formed.

Exception: An area on the inside surface of an enclosure that is not exposed to water during the water spray test is not required to be painted.

**UL COPYRIGHTED MATERIAL –
NOT AUTHORIZED FOR FURTHER REPRODUCTION OR
DISTRIBUTION WITHOUT PERMISSION FROM UL**

58 Gaskets

58.1 This section applies to gaskets that are required for an electrical enclosure to maintain a tight fit.

58.2 A gasket shall be secured with adhesive or by mechanical means, including force-fit or the combination of the gasket's shape and elastomeric properties. The gasket and its securing means shall not be damaged when the cover is opened.

58.3 The gasket material and adhesive combination, if applicable, shall comply with the Standard for Gaskets and Seals, UL 157. The Tensile Strength Test and Ultimate Elongation Test, when tested in accordance with the Standard for Gaskets and Seals, UL 157, shall have a tensile strength of no less than 60 percent and an elongation of no less than 75 percent of the values determined before conditioning.

59 Supply Connections

59.1 A conduit opening in the enclosure of a fixed power unit shall be evaluated in accordance with Sections 67 – 71.

59.2 The power supply cord provided with a power unit intended for use in an outdoor location shall be at least as serviceable as junior hard service cord type SJW, SJOW, SJTW, SJTOW, SW, SOW, STW, or STOW.

59.3 An outdoor power unit shall be provided with means for connection of the supply with one of the following:

- a) Terminals or leads for permanent connection to the supply for fixed equipment. A lead shall be no less than 152.4 mm (6 inches) in length and shall not exceed 609.6 mm (24 inches) in length. The requirements of Sections 67 – 71 shall also apply;
- b) A non-detachable power supply cord for connection to the supply by means of a plug; or
- c) A direct plug-in unit.

59.4 A cord-connected power unit intended for use in an outdoor location shall employ a 3-conductor grounding type supply cord.

Exception: A power unit that does not have parts required to be grounded is not required to employ a grounding type supply cord.

60 Output Connections and Wiring

60.1 Output wiring shall be suitable for outdoor use, "W" rated, and sunlight-resistant as applicable to outdoor cords.

60.2 An output connection shall be suitable for outdoor use, protected against corrosion, and sunlight-resistant as applicable to outdoor connections.

61 Spacings

61.1 A unit intended for outdoor use shall comply with Section 24, Spacings, except that 24.1 and 24.5 – 24.8 shall be replaced with 61.2.

61.2 The spacing between live parts of opposite polarity, live and dead metal parts, and live parts and a metal enclosure, shall be as specified in Table 24.1. This table applies to units with or without openings.

Exception No. 1: A unit complying with the hose down test specified in the Standard for Enclosures for Electrical Equipment, Non-Environmental Considerations, UL 50, may be evaluated in accordance with Table 24.2.

Exception No. 2: The spacing requirements within the Standard for Insulation Coordination Including Clearances and Creepage Distances for Electrical Equipment, UL 840, may be used as an alternative to the spacing requirements located in Table 24.1. If UL 840 is used, the following shall apply:

- a) The spacing requirement of UL 840 shall not be used for field wiring terminals or for spacings to a dead metal enclosure;*
- b) The level of pollution for damp location and outdoor use equipment is pollution degree 3. A hermetically sealed or encapsulated enclosure, or a coated printed wiring board in compliance with the Printed Wiring Board Coating Performance Test of the Standard for Insulation Coordination Including Clearances and Creepage Distances for Electrical Equipment, UL 840, is classified pollution degree 1;*
- c) The equipment is rated overvoltage category I and overvoltage category II as defined in the Standard for Insulation Coordination Including Clearances and Creepage Distances for Electrical Equipment, UL 840; and*
- d) Control of overvoltage shall be achieved by providing an overvoltage device or system as an integral part of the product in order to apply Clearance B (controlled overvoltage) clearances. The device shall comply with the Standard for Surge Protective Devices, UL 1449.*

62 Accessibility of Live Parts

62.1 A unit intended for outdoor use shall comply with Section 16, Accessibility of Live Parts, except that 16.2.2 and 16.3.2 shall be replaced with 62.2 and 62.3, respectively.

62.2 The maximum voltages which may be accessible in accordance with 16.2.1 are:

- a) 15 V for sinusoidal AC and 21.2 V peak for nonsinusoidal AC;
- b) 30 V for continuous DC, or 30 V peak for interrupted DC outside the range of 10 – 200 Hz; and
- c) 12.4 V peak for DC interrupted at a rate of 10 – 200 Hz.

An initial transient lasting less than 200 milliseconds may be disregarded. Voltages are to be monitored using a storage oscilloscope for the first two seconds after any fault is introduced.

62.2 revised October 11, 2013

62.3 The maximum voltages which may be accessible in accordance with 16.3.1 are:

- a) 15 V for sinusoidal AC and 21.2 V peak for nonsinusoidal AC;
- b) 30 V for continuous DC, or 30 V peak for interrupted DC outside the range of 10 – 200 Hz; and
- c) 12.4 V peak for DC interrupted at a rate of 10 – 200 Hz.

62.3 revised October 11, 2013

63 Ground-Fault Circuit-Interrupters

63.1 Each power unit shall be protected by an integral ground-fault circuit-interrupter that complies with the requirements for a Class A ground-fault circuit-interrupter in the Standard for Ground-Fault Circuit-Interrupters, UL 943.

Exception: An integral ground-fault circuit-interrupter is not required if the unit is marked in accordance with 65.2.

63.2 If provided, a ground-fault circuit-interrupter (including any external open-neutral circuitry) shall be connected between the supply lead or terminal connections and all other electrical conductors and equipment. This determination is to be made with the unit connected in all intended voltage configurations.

63.3 In a power unit, the conductors on the load side of the ground-fault circuit-interrupter shall not occupy boxes or enclosures containing other conductors unless the additional conductors are also protected by a ground-fault circuit-interrupter.

Exception: Conductors on the load side of a ground-fault circuit-interrupter may occupy the same boxes or enclosures as other conductors if the conductors are separated by a barrier or if the conductors are segregated, routed, or secured to provide permanent spacing from all other insulated or uninsulated live parts.

63.4 A ground-fault circuit-interrupter test button shall be accessible without the use of tools.

64 Performance

64.1 General

64.1.1 All applicable tests in this Standard affected by ambient temperature fluctuations shall be tested using the ambient identified by the manufacturer. If the specified ambient is less stringent than minus 35°C to 40°C then the ambient to be used is minus 35°C to 40°C.

64.2 Abuse tests

64.2.1 A unit for use in an outdoor location shall comply with Section 46, Abuse Tests. In addition 46.2, 46.3, and 46.5 shall be repeated as specified in Section 46, except the drop test is to be applied on a concrete surface. Before the tests identified in 46.2, 46.3, and 46.5, the sample is to be cooled to a temperature of minus 35.0 ±2.0°C (minus 31.0 ±3.6°F) and maintained at this temperature for a minimum of 3 hours. Testing is to commence immediately upon removal from the cooling . One sample may be utilized for each test, however all samples shall comply with 64.2.2.

64.2.1 revised January 26, 2012

64.2.2 After completion of the tests specified in 64.2.1, each sample shall comply with 46.1.1 and 46.1.2, and shall be subjected to the Dielectric Voltage Withstand Test. An examination shall be conducted for evidence of the development of a risk of fire or electric shock. The Rain Test, 64.3, and the Standing Water Immersion Test, 64.4, shall be conducted if applicable.

64.3 Rain test

64.3.1 An enclosure designated rainproof or raintight shall be subjected to a water spray as described in 64.3.5. A rainproof enclosure shall have no wetting of a live part nor have entrance of water above the lowest live part. A raintight enclosure shall have no entrance of water into the enclosure.

64.3.2 The power unit is to be mounted as if in actual service for the test required in 64.3.1. A fixed power unit is to be fitted with rigid conduit, without using pipe-thread compounds. A portable or stationary power unit is to be positioned as if in intended use.

64.3.3 The rain test is to be repeated on other sides of the enclosure as necessary unless the construction is such that a test on one side is representative of a test on another side.

64.3.4 After being subjected to the rain test for the specified time in 64.3.5, a power unit intended for outdoor use shall:

- a) Comply with the requirements for the Leakage Current Test, Section 26. The test is to be discontinued when the leakage current stabilizes; and
- b) Comply with the Dielectric Voltage Withstand Test, Section 34.

64.3.5 The rain test apparatus is to consist of three spray heads constructed in accordance with the details shown in Figure 64.1 and mounted in a water-supply pipe rack as shown in Figure 64.2. The water pressure for all tests is to be maintained at 5.0 pounds per square inch (34 kPa) at each spray head. The distance between the center nozzle and the power unit is to be approximately 1.5 m (5.0 feet). The power unit is to be brought into the focal area of the three spray heads in such a position and under such conditions as are most likely to result in the entrance of water into the power unit, except that

*UL COPYRIGHTED MATERIAL –
NOT AUTHORIZED FOR FURTHER REPRODUCTION OR
DISTRIBUTION WITHOUT PERMISSION FROM UL*

No Text on This Page

***UL COPYRIGHTED MATERIAL –
NOT AUTHORIZED FOR FURTHER REPRODUCTION OR
DISTRIBUTION WITHOUT PERMISSION FROM UL***

consideration is to be given to the intended mounting position. A power unit employing a fan or other moving part, in which the operation is likely to facilitate the entrance of water, is to be energized and operated in the intended manner. The spray is to be applied for 1 hour.

64.3.6 The test is to be conducted using water with a resistivity of 200 ohms-meter. The water resistivity is to be obtained by the addition of sodium chloride (common-table salt) to tap water; distilled water is not to be used.

Figure 64.1
Spray-head
PLAN VIEW

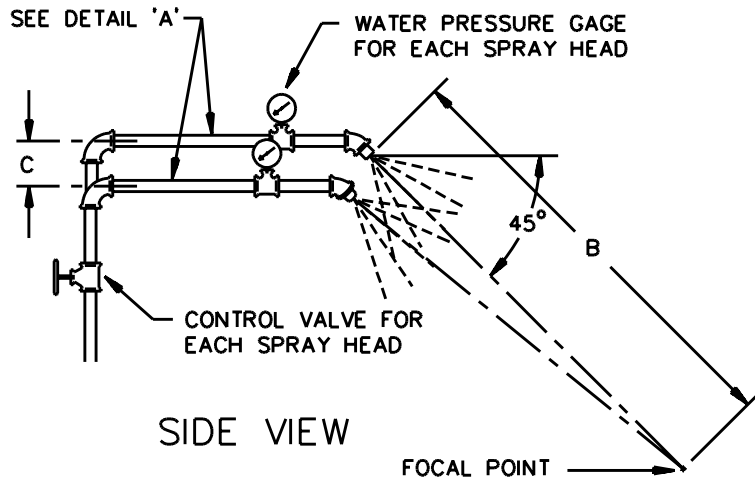
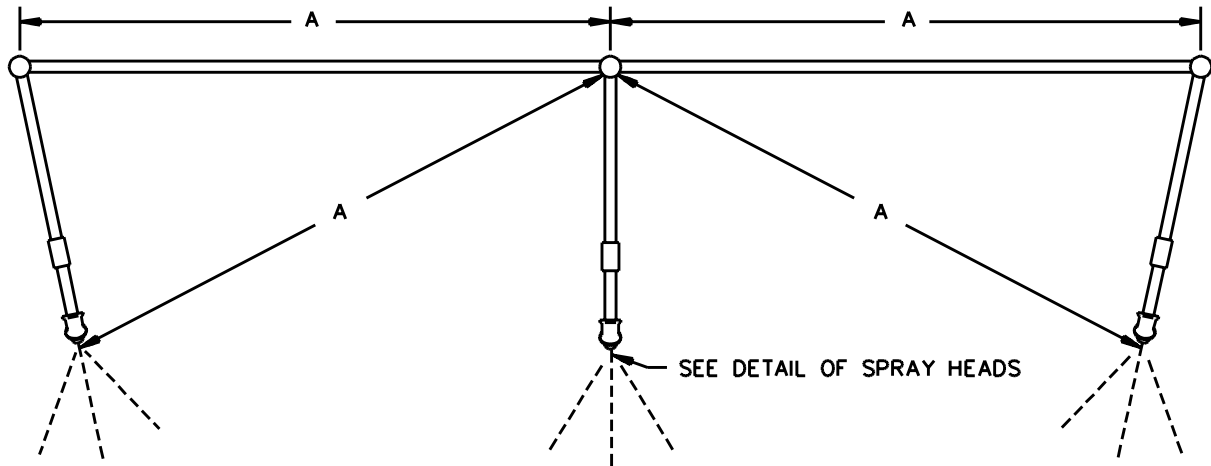

PIEZOMETER ASSEMBLY
DETAIL 'A'

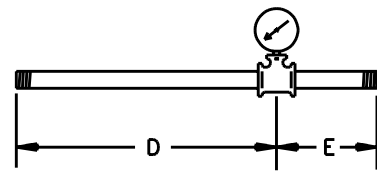

SIDE VIEW

Item	mm	inch
A	710	28
B	1400	55
C	55	2-1/4
D	230	9
E	75	3

RT101H

*UL COPYRIGHTED MATERIAL –
NOT AUTHORIZED FOR FURTHER REPRODUCTION OR
DISTRIBUTION WITHOUT PERMISSION FROM UL*

Figure 64.2
Water-spray piping

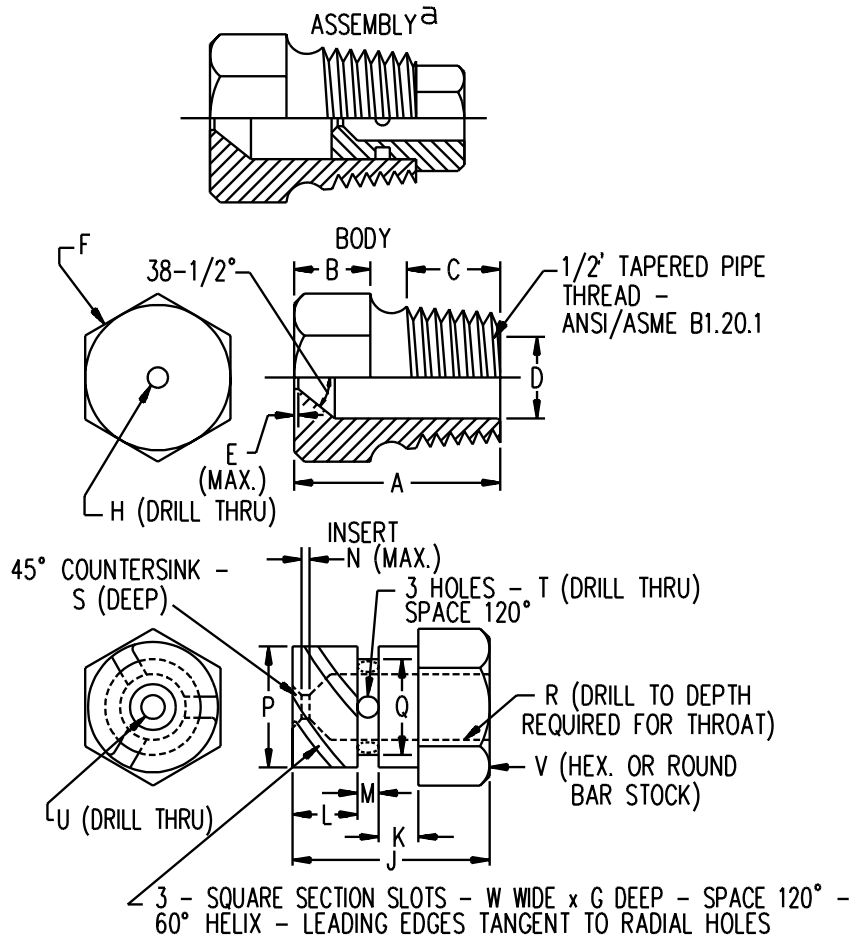

Item	mm	inch	Item	mm	inch
A	31.0	1-7/32	N	0.80	1/32
B	11.0	7/16	P	14.61	.575
C	14.0	9/16		14.63	.576
D	14.68	.578	Q	11.51	.453
	14.73	.580		11.53	.454
E	0.40	1/64	R	6.35	1/4
F	c	c	S	0.80	1/32
G	1.52	.06	T	2.80	(No. 35) ^b
H	5.0	(No.9) ^b	U	2.50	(No. 40) ^b
J	18.3	23/32	V	16.0	5/8
K	3.97	5/32	W	1.52	0.06
L	6.35	1/4			
M	2.38	3/32			

^a Nylon Rain-Test Spray Heads are available from Underwriters Laboratories

^b ANSI B94.11M Drill Size

^c Optional - To serve as a wrench grip.

RT100F

**UL COPYRIGHTED MATERIAL -
NOT AUTHORIZED FOR FURTHER REPRODUCTION OR
DISTRIBUTION WITHOUT PERMISSION FROM UL**

64.4 Standing water immersion test

64.4.1 The construction of a power unit designated for outdoor use, or any other outdoor-use product enclosure, mounted within 304.8 mm (1 foot) from the ground shall prevent the entrance of water into the interior space of the enclosure.

64.4.2 Each product is to be operated at room temperature for 3-1/2 hours. The product is then to be de-energized and immediately submerged in at least 304.8 mm (1 foot) of water. The temperature of the water before submersion is to be 5°C (41°F) or less. The product is to remain submerged for 4 hours. At the end of four hours, the product is to be removed from the water and subjected to 2 additional cycles of operation and immersion. Between each cycle, the product is to be placed in a dry location at room temperature for approximately 16-1/2 hours. The product is to be inspected immediately after the third immersion for evidence of water entry.

64.4.3 After being subjected to the standing water immersion test for the time specified, a power unit intended for outdoor use shall comply with the following:

- a) The requirements for the Leakage Current Test, Section 26, with the test being discontinued when the leakage current stabilizes; and
- b) The Dielectric Voltage Withstand Test, Section 34.

65 Markings

65.1 A required marking shall be capable of withstanding the stresses of ordinary usage, including exposure to weather and other ambient conditions, handling, storage, and similar conditions. An adhesive-backed label shall comply with the requirements in the Standard for Marking and Labeling Systems, UL 969, for the exposure conditions and surface temperatures of minimum range from 80°C (176°F) to minus 35°C (minus 31°F). If a tag is utilized, it shall be permanent and tear resistant.

65.2 An outdoor use power unit complying with the Exception to 63.1 shall be provided with a marking that consists of the following or equivalent wording:

- a) For a permanently connected power unit:

“WARNING: Risk of Electric Shock. Install only on a circuit protected by a Class A GFCI.”

- b) For a cord connected or direct plug-in power unit:

“WARNING: Risk of Electric Shock. Install only to a covered Class A GFCI receptacle that has an enclosure that is weatherproof with the attachment plug cap inserted or removed.”

65.3 An outdoor unit shall be marked “raintight” or “rainproof” in accordance with 64.3.1.

65.4 In accordance with 56.9, a direct plug-in power unit shall be marked “WARNING: Not for use with receptacles that are weatherproof only when the receptacle is covered (attachment plug cap not inserted and receptacle cover closed).”

**UL COPYRIGHTED MATERIAL –
NOT AUTHORIZED FOR FURTHER REPRODUCTION OR
DISTRIBUTION WITHOUT PERMISSION FROM UL**

65.5 A permanently connected unit shall be marked in accordance with Section 70, Markings.

65.6 In accordance with 56.3, a unit intended to be mounted greater than 0.30 m (1 foot) from the ground surface shall be marked as follows: "WARNING: Risk of Electric Shock. Mount the unit at a height greater than 1 foot from the ground surface."

66 Instructions

66.1 The text of the safety instructions required by 66.3 shall be verbatim, or in equally definitive terminology, unless otherwise indicated.

Exception: A variation from the specified wording may be used if a specific conflict of the application to a product exists.

66.2 The items in the list in 66.3 shall be numbered and may include additional important safety instructions deemed appropriate by the manufacturer.

66.3 The important safety instructions shall be provided with a power unit and include those items in the following list that are applicable. The statement "READ AND FOLLOW ALL SAFETY INSTRUCTIONS" shall be prominently displayed and precede the list, and the statement "SAVE THESE INSTRUCTIONS" shall be prominently displayed and follow the list. The word "WARNING" shall be entirely in upper case letters.

IMPORTANT SAFETY INSTRUCTIONS

When using electrical products, basic precautions should always be practiced including the following:

1. READ AND FOLLOW ALL SAFETY INSTRUCTIONS.
2. Read and follow all instructions that are on the product or provided with the product.
3. For a cord-connected or direct plug-in power unit, do not use an extension cord.
4. Reference the National Electrical Code, ANSI/NFPA 70, specifically for the installation of wiring and clearances from power and lighting conductors.
5. Installation work and electrical wiring must be done by qualified person(s) in accordance with all applicable codes and standards, including fire-rated construction.
6. For a cord-connected or direct plug-in power unit, do not install or use within 10 feet of a pool.
7. For a cord-connected or direct plug-in unit, do not use in a bathroom.
8. For a direct plug-in or cord-connected power unit marked in accordance with 65.2:

WARNING: Risk of Electric Shock. When used outdoors, install only to a covered Class A GFCI protected receptacle that is weatherproof with the power unit connected to the receptacle. If one is not provided, contact a qualified electrician for proper installation. Ensure that the power unit and cord do not interfere with completely closing the receptacle cover.

**UL COPYRIGHTED MATERIAL –
NOT AUTHORIZED FOR FURTHER REPRODUCTION OR
DISTRIBUTION WITHOUT PERMISSION FROM UL**

9. For a permanently connected power unit marked in accordance with 65.2:

WARNING: Risk of Electric Shock. When used outdoors, install only on a circuit protected by a Class A GFCI.

10. WARNING: Risk of Fire. Installation involves special wiring methods to run wiring through a building structure. Consult a qualified electrician.

11. For a unit intended to be mounted greater than 0.30 m (1 foot) from the ground surface:

WARNING: Risk of Electric Shock. Mount the unit at a height greater than 1 foot from the ground surface.

SAVE THESE INSTRUCTIONS – This manual contains important safety and operating instructions for power units.

66.4 A permanently connected unit shall be provided with instructions in accordance with Section 71, Installation Instructions.

66.5 For direct plug-in units, in accordance with 56.9, the installation instructions shall be provided with a warning to the user, using pictorials or equally effective means, not to use with receptacles that are weatherproof only when the receptacle is covered (attachment plug cap not inserted and receptacle cover closed).

66.6 With reference to instruction item 10 in 66.3, there shall be no literature, carton markings, or illustrations depicting or implying running wiring through a building structure.

PERMANENTLY-CONNECTED UNITS FOR CONNECTION TO A WIRING SYSTEM

67 General

67.1 The requirements in Sections 67 – 71 supplement and, in some cases, modify the general requirements in Sections 1 – 66. This section is intended to cover the requirements for power units connected to the supply via a permanently connected wiring system. These requirements do not apply to power units intended for installation in outlet boxes (see Sections 71A – 71H).

67.1 revised April 26, 2013

**UL COPYRIGHTED MATERIAL –
NOT AUTHORIZED FOR FURTHER REPRODUCTION OR
DISTRIBUTION WITHOUT PERMISSION FROM UL**

68 Construction

68.1 A permanently-connected power unit shall have a provision for the connection of a wiring system in accordance with Sections 67 – 71.

68.2 A power unit supply conductor shall be sized in accordance with the National Electrical Code, ANSI/NFPA 70, as appropriate for the branch circuit specified.

68.3 A knockout in a sheet-metal enclosure shall be secured and removable without undue deformation of the enclosure.

68.4 A knockout shall be surrounded by a flat surface to accommodate for seating of a conduit bushing or locknut of the appropriate size.

68.5 There shall be three to five threads in the metal when threads for the connection of conduit are tapped all the way through a hole in an enclosure wall, or when an equivalent construction is employed. The construction of the device shall be such that a conduit bushing is able to be properly attached.

68.6 Threads for the connection of conduit that are not tapped all the way through a hole in an enclosure wall, conduit hub, or similar construction shall not be less than 3-1/2 threads in the metal. There shall be a smooth, rounded inlet hole for the conductors that shall provide protection to the conductors equivalent to that provided by a standard conduit bushing, and shall have an internal diameter similar to the corresponding trade size of a rigid conduit.

68.7 A field-wiring compartment in which power unit connections are to be made shall:

- a) Be located so that the connections may be readily inspected after the power unit is installed;
- b) Permit the connection to be introduced and connected easily; and
- c) Permit the connection of the supply wires after the power unit is fixed to its support.

Exception: A power unit weighing five pounds or less is permitted for external mounting on an outlet box cover plate.

68.8 A field-wiring compartment intended for connection of a wiring system shall be attached to the power unit to prevent turning.

68.9 An outlet box, terminal box, wiring compartment, or similar component, in which connections to the power unit circuit are made in the field shall be free from any sharp edge including screw threads, a burr, a fin, a moving part, or similar component that may abrade the insulation on conductors, or otherwise damage the wiring.

68.10 The outlet box, terminal box, wiring compartment, or similar component, in which connections to the power unit circuit are made in the field shall comply with the applicable requirements in the Standard for Metallic Outlet Boxes, UL 514A, the Standard for Nonmetallic Outlet Boxes, Flush-Device Boxes, and Covers, UL 514C, or the Standard for Enclosures for Electrical Equipment, Non-Environmental Considerations, UL 50.

**UL COPYRIGHTED MATERIAL –
NOT AUTHORIZED FOR FURTHER REPRODUCTION OR
DISTRIBUTION WITHOUT PERMISSION FROM UL**

68.11 A hole for the connection of conduit shall not be drilled and tapped in the field.

68.12 The equipment shall be provided with cable entries, conduit entries, knock-outs, or glands, that allow connection of the appropriate types of cables or conduits.

69 Wiring Terminals and Leads

69.1 The field-wiring terminals in 68.3 – 68.12 are terminals to which supply connections are made in the field when the power unit is installed.

69.2 A field-wiring terminal, or lead, shall be sized for the connection of conductors having an ampacity rated for the specified branch circuit overcurrent protection of the power unit.

69.2A A field-wiring lead shall consist of general building wire rated minimum 600 V. It shall not be more than two standard wire sizes smaller than the copper conductor to which it will be connected and shall not be smaller than 18 AWG (0.82 mm²). An 18 AWG field wiring lead shall not be longer than 12 inches (305 mm).

Exception: An 18 AWG size field-wiring lead may be provided for connection to a No. 12 (3.3 mm²) size branch circuit conductor.

69.2A added April 26, 2013

69.3 The grounding conductor shall:

- a) Not be smaller in size than the line and neutral conductors; and
- b) Not be identified for the connection of an aluminum conductor.

69.4 The power unit shall have all associated terminals located in proximity to each other and to the grounding terminal, if any.

69.5 The terminal block shall comply with the requirements for a terminal block suitable for field wiring using the applicable wire gauge in the Standard for Equipment Wiring Terminals for Use with Aluminum and/or Copper Conductors, UL 486E.

69.6 The connection of the grounding conductor shall be in accordance with the applicable requirements located in the Standard for Wire Connectors, UL 486A-486B, and shall be suitable for grounding and bonding equipment.

69.7 Metal employed for an equipment-grounding terminal shall be nonferrous, stainless steel, or of other metal that is inherently resistant to corrosion.

69.8 A wiring terminal shall be prevented from turning or shifting in position by a means other than friction between surfaces. This may be accomplished by two screws or rivets, square shoulders or mortises, a dowel pin, lug or offset, a connecting strap, a clip fitted into an adjacent part, or an equivalent method.

**UL COPYRIGHTED MATERIAL –
NOT AUTHORIZED FOR FURTHER REPRODUCTION OR
DISTRIBUTION WITHOUT PERMISSION FROM UL**

69.9 The free length of a lead inside an outlet box or wiring compartment shall be at least 152 mm (6.0 inches) and shall not exceed 609.6 mm (24.0 inches) in length if the lead is for field connection to an external circuit.

69.10 The wiring compartment for the supply connections shall not occupy the same space for any of the Class 2 wiring.

69A Strain Relief Test

69A.1 A wiring lead intended for field-wiring connection shall withstand without damage or displacement, a direct pull of:

- a) 20 pounds (89 N) for 1 minute applied to a lead extending from the enclosure (such as through a knockout); and
- b) 10 pounds (44.5 N) for 1 minute applied to a lead within a wiring compartment.

69A.1 added April 26, 2013

No Text on This Page

***UL COPYRIGHTED MATERIAL –
NOT AUTHORIZED FOR FURTHER REPRODUCTION OR
DISTRIBUTION WITHOUT PERMISSION FROM UL***

70 Markings

70.1 In addition to the markings specified in this Standard, a permanently connected power unit shall be provided with the following markings:

- a) The type of conductors to be utilized, for example, "use copper conductors only";
- b) A terminal intended for connection of grounded power supply conductor shall be made of or plated with metal substantially white or gray in color and shall be readily distinguishable from other terminals;

Exception: This requirement does not apply when proper identification of a terminal that is intended for connection of grounded power supply conductor is clearly shown in some other manner, such as on an attached wiring diagram or adjacent marking letter "N" or "Common".

- c) The surface of a lead for the connection of a grounded power supply conductor shall be white or gray and shall be readily distinguishable from the other leads;
- d) The line conductor or the connection of the line conductor shall be easily distinguishable from the other connections, for example, adjacent marking letter "L";
- e) The terminal for the connection of the equipment grounding terminal, shall be identified by:
 - 1) A green colored terminal hexagonal screw, hexagonal nut, or a green colored pressure wire connector;
 - 2) The marking "G", "GND", or "GROUND" at or near the grounding terminal; or
 - 3) The grounding symbol illustrated in Figure 70.1, on or adjacent to the terminal.
- f) If the wiring compartment attains a temperature above 60°C (140°F) during normal operation, the unit shall be marked near the point at which the supply connections are made with the minimum temperature rating of the conductors that must be used; and
- g) The tightening torque, if applicable for wiring terminals.

70.2 A permanently connected unit that exceeds the surface temperature limits specified in Table 33.1 for either metallic or nonmetallic surfaces shall be legibly marked where readily visible after installation with the signal word of 52.1 and the following or the equivalent: "HOT SURFACES – Risk of Burns – Do not touch."

70.2 added May 30, 2014

Figure 70.1
Grounding Symbol

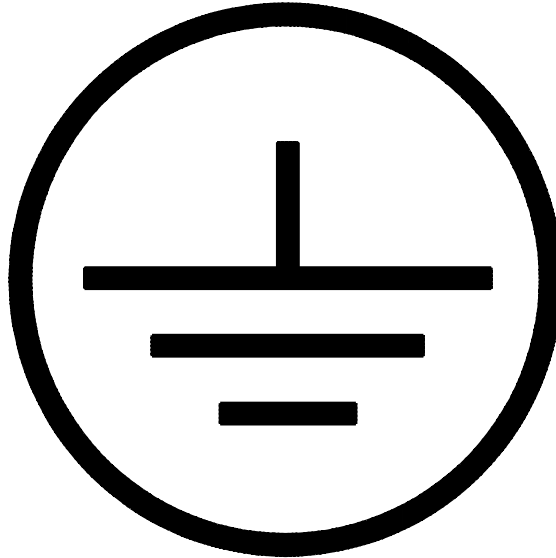

IEC417, Symbol 5019

71 Installation Instructions

71.1 In addition to the instructions specified in this Standard, a permanently connected power unit shall be provided with the instructions specified in this Section.

71.2 The instruction manual shall include the following:

- a) Information identifying the procedure for connection to the supply;
- b) Number of conductors;
- c) Branch circuit size;
- d) Tightening torque;
- e) Range of conductor sizes;
- f) Minimum temperature rating of the conductor; and
- g) The following or equivalent text: "A disconnect device shall be incorporated in the field wiring."

*UL COPYRIGHTED MATERIAL –
NOT AUTHORIZED FOR FURTHER REPRODUCTION OR
DISTRIBUTION WITHOUT PERMISSION FROM UL*

71.3 The installation instructions shall also make reference indicating installation work and electrical wiring of permanently-connected power units shall be performed only by qualified service personnel in accordance with all applicable codes and standards, including fire-rated construction.

PERMANENTLY-CONNECTED UNITS FOR INSTALLATION IN AN OUTLET BOX

71A General

71A.1 The requirements in Sections 71A – 71H supplement and, in some cases, modify the general requirements in Sections 1 – 71. This section applies to power units intended for flush installation in an outlet box for fixed installation on a branch circuit (outlet box power unit).

71A.1 added April 26, 2013

71A.2 These requirements do not apply to the enclosure or any part which forms the enclosure, including the outlet box, flush device cover plate, or both.

71A.2 added April 26, 2013

71A.3 These requirements only apply to a power unit with only Class 2 outputs. Combination products consisting of a branch circuit receptacle(s) and Class 2 output(s) are covered under the Standard for Attachment Plugs and Receptacles, UL 498.

71A.3 added April 26, 2013

71B Construction

71B.1 An outlet box power unit shall be provided with a suitable flush device cover plate or outlet box cover that complies with the applicable requirements of the Standard for Cover Plates for Flush-Mounted Wiring Devices, UL 514D.

Exception: A unit need not be provided with a cover plate or box cover if all the following conditions are met:

a) The unit is intended for use with a cover plate having dimensions that comply with the Standard for Wiring Devices - Dimensional Specifications, ANSI/NEMA WD6, for features intended to accommodate a flush-mounted wiring device of the dimensions specified in ANSI/NEMA WD6;

b) Markings specified in Section 71H, Markings, are visible after installation using a cover plate having dimensions specified in (a); and

c) No cover plate modifications are needed in order to comply with this Standard.

71B.1 revised October 11, 2013

71B.2 The output connectors shall be insulated and extend beyond the plane of the power unit mounting yoke.

71B.2 added April 26, 2013

71C Polymeric Enclosures

71C.1 A polymeric material used to enclose the power unit circuitry shall have a flame rating not less than 5V, in accordance with the Standard for Tests for Flammability of Plastic Materials for Parts in Devices and Appliances, UL 94, or comply with the 127 mm Flame Test specified in the Standard for Polymeric Material - Use in Electrical Equipment Evaluations, UL 746C.

71C.1 added April 26, 2013

71D Spacings

71D.1 A power unit shall be constructed such that, after installation, a minimum of a 1/4 inch (6.35 mm) separation can be maintained between branch circuit wiring and circuitry associated with any Class 2 output. Compliance is checked by measurement and if necessary, by conducting the Assembly Test in 71E.2.

71D.1 added April 26, 2013

71D.2 A power unit shall provide clearance of 3/64 inch (1.2 mm) between each input terminal and the metal of a standard outlet box of the minimum size in which it is intended to be installed. Compliance is checked by conducting the Assembly Test in 71E.2.

71D.2 added April 26, 2013

71E Performance

71E.1 General

71E.1.1 For all testing where the power unit is to be energized from a source of supply, the power unit is to be assembled as intended into a nonmetallic outlet box with a depth as specified by the manufacturer. The outlet box is to be mounted in a vertical wall section as follows:

- a) With a depth of minimum 125 percent of the box depth;
- b) With plywood or gypsum wallboard surfaces; and
- c) Loosely filled with fiberglass or equivalent thermal insulation.

71E.1.1 added April 26, 2013

71E.2 Assembly test

71E.2.1 A power unit shall:

- a) Maintain a minimum of a 1/4 inch (6.35 mm) separation of branch circuit wiring and circuitry associated with any Class 2 output;
- b) Maintain adequate clearance between each input terminal and the metal of a standard outlet box of the minimum size in which it is intended to be installed; and
- c) Not permit contact to be made between the probe shown in Figure 71E.1 and any live part through the output connectors or through any flush device cover plate or outlet box cover opening or joint surrounding the installed power unit.

71E.2.1 added April 26, 2013

**Figure 71E.1
Small test probe**

Figure 71E.1 added April 26, 2013

0.031±0.002 In. diameter

0.002 In. radius on corner

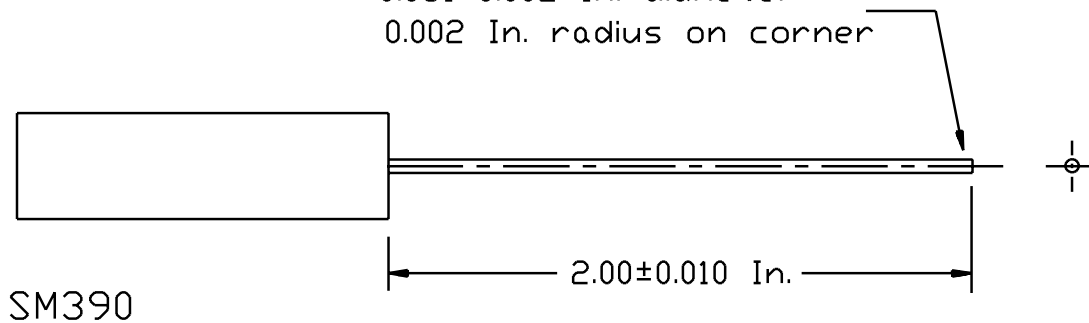

MATERIAL: Tool Steel, Rockwell Hardness C58 to C60

Dimensions and the equivalent unit conversions:

Inch	(mm)
0.031 ±0.002	(0.787 ±0.051)
2.00 ±0.010	(50.8 ±0.25)

71E.2.2 A power unit is to be wired with the largest conductor (AWG) size when installed into the minimum size metallic outlet box, as indicated in the manufacturer’s instructions. The conductor length is to be 6 inches (152 mm).

71E.2.2 added April 26, 2013

71E.2.3 Following assembly, the power unit shall be checked for compliance with 71E.2.1 (a) and (b). Additionally, with the flush-device cover plate or outlet box cover installed, the probe is to be applied to any opening or joint surrounding the output connector and through the output connector slot openings with a force of 8 ounces (2.2 N) in attempt to contact live parts. A suitable indicating device (such as an ohmmeter, battery-and-buzzer combination, or similar device) is to be connected between the probe and the input terminals to determine whether contact is made. The rod is to be inserted in the output connector slot opening successively in three directions in any orientation that may permit access to contact live parts. The probe is to be applied for approximately 5 seconds in each of the three directions. During each application the gauge shall not be moved or rotated and shall be withdrawn when moving from one direction to the next.

71E.2.3 added April 26, 2013

71F Installation Instructions

71F.1 A power unit shall be provided with installation instructions. These instructions shall be provided with each individual device and contain the following information:

- a) The dimensions of the intended outlet box necessary to mount and secure the power unit; and
- b) The largest branch circuit conductor size in AWG the device will accommodate.

71F.1 added April 26, 2013

71F.2 Instructions shall include information to alert the user that a single branch circuit shall supply the device. The instructions shall include a pictorial or photograph illustrating proper installation and wiring method of conductors.

71F.2 added April 26, 2013

71G User Instructions

71G.1 Each smallest unit packaging shall include user instructions with information regarding:

- a) The use of appropriate Class 2 connectors with interconnecting cables; and
- b) That Class 2 output connections are not intended for supporting products or appliances.

71G.1 added April 26, 2013

71H Markings

71H.1 The output connectors shall be identified as being Class 2 and marked with the output electrical rating. The output electrical rating shall be permanently marked and visible after installation of the flush device cover plate or outlet box cover.

71H.1 added April 26, 2013

POWER UNITS FOR INSTALLATION IN AIR-HANDLING SPACES

72 General

72.1 The requirements in Sections 72 and 73 apply to a power unit intended for installation in air handling spaces, such as above suspended ceilings or below floors.

72.2 A power unit shall be a permanently connected type for input and output connections.

72.3 A power unit shall not employ an integral battery.

72.4 A power unit shall comply with the Standard for Fire Test for Heat and Visible Smoke Release for Discrete Products and Their Accessories Installed in Air-Handling Spaces, UL 2043.

72.4 revised October 11, 2013

No Text on This Page

***UL COPYRIGHTED MATERIAL –
NOT AUTHORIZED FOR FURTHER REPRODUCTION OR
DISTRIBUTION WITHOUT PERMISSION FROM UL***

73 Marking

73.1 A power unit may be marked as follows: "Suitable for use in other environmental air space in accordance with Section 300.22(C) of the National Electrical Code" or "Suitable for use in air-handling spaces."

POWER UNITS SUPPLIED FROM INFORMATION TECHNOLOGY EQUIPMENT DATA PORTS

74 General

74.1 These requirements apply to a power unit with a direct current input jack for being powered from a data port associated with information technology equipment. These requirements supplement and modify the requirements of Sections 3 – 54.

75 Glossary

75.1 ITE – Information technology equipment.

76 Supply Connections

76.1 A unit shall be provided with a maximum 10 ft (3.05 m) length of cable for interconnection to the ITE. The cable shall be stranded conductors having insulation not less than 0.013 inch (0.33 mm) thick, and shall terminate in a data port connector.

76.2 With respect to 76.1, for units with jacketed multi-conductor cable for interconnection to the ITE, the individual conductor insulation may be less than 0.013 inch (0.33 mm) provided that the thickness of the individual conductor insulation plus the thickness of the jacket is not less than 0.013 inch (0.33 mm).

77 Enclosure

77.1 When applying the requirements of Section 8, Enclosure, and the Standard for Polymeric Materials – Use in Electrical Equipment Evaluations, UL 746C, it shall be anticipated that the ITE supply source has a capacity of 8 amperes and 100 volt-amperes.

78 Performance

78.1 General

78.1.1 If a unit may be operated from more than one source of supply simultaneously, the unit shall comply with the following requirements when connected to the sources of supply individually and collectively:

- a) Section 28, Maximum Output Voltage Test;
- b) Section 30, Output Current and Power Test;
- c) Section 33, Normal Temperature Test;
- d) Section 39, Abnormal Tests;
- e) 39.2, Output Loading;
- f) 39.4, Transformer Burnout;
- g) 39.5, Reverse Polarity;
- h) 39.6, Switch Position;
- i) 39.7, Component Breakdown;
- j) 39.9, Backfeed Protection; and
- k) 78.2, Abnormal Temperature Test.

78.1.2 During the test of 78.1.1, the input intended for connection to ITE shall be connected to its rated voltage.

78.2 Abnormal temperature test

78.2.1 A unit shall not emit flame or molten metal or become a risk of fire or electric shock (see 39.1.2) when subjected to the test in 78.2.2.

78.2.2 While still in a heated condition following the Normal Temperature Test (see 78.1.1 and Section 33, Normal Temperature Test) and without further adjustment of the load, the input intended for connection to ITE is to be connected to a variable voltage source adjusted to result in the maximum current but not exceeding 8 amperes and 100 VA, and not exceeding 60 Vdc. A manually reset protector is to be operated for 10 cycles and the protector contacts shall be operative upon completion of the test. If an automatic reset protector is provided, or the input current is a value other than zero, the test is to be continued for 7 hours.

78.3 Strain relief test

78.3.1 An attached input cable for interconnection to the ITE is to withstand a 20 pounds-force (89 N) applied for 1 minute so that the strain relief means is stressed from the most severe angle that the construction permits. The results are acceptable if, with the input wiring connected internally, movement of the cable does not result in:

- a) A reduction of electrical spacings to primary and dead metal parts;
- b) Damage to the transformer or enclosure; or
- c) Interruption of the input wiring.

79 Markings

79.1 The input intended for connection to ITE shall be marked with its rated input voltage, "dc" and rated input current, wattage or volt-amperes.

79.2 The unit shall be marked "CAUTION – Risk of Injury and Fire" and one of the following or equivalent:

- a) "Connect only to equipment specified in the instructions" (see 80.1); or
- b) "Connect only to [type] certified to meet the Standard for Information Technology Equipment Safety – Part 1: General Requirements, UL 60950-1."

The [type] shall be filled in with the type of ITE to which it may be connected which complies with the Standard for Information Technology Equipment Safety – Part 1: General Requirements, UL 60950-1 (for example "a data port on equipment").

80 Instructions

80.1 The instructions shall state “CAUTION – Risk of Injury and Fire.” The statement shall be followed by instructions specifying the type of ITE to which it may be connected which complies with the Standard for Information Technology Equipment Safety – Part 1: General Requirements, UL 60950-1. For example, the instruction may state “Connect only to a data port on equipment certified to meet the Standard for Information Technology Equipment Safety – Part 1: General Requirements, UL 60950-1.”

Exception: The instruction is not required for a unit marked in accordance with 79.2(b).

FLUSH DEVICE COVER PLATES WITH INTEGRAL POWER SUPPLY

81 General

81.1 The requirements in Sections 81 – 89 apply to a flush device cover plate with integral power supply with Class 2 output connector(s) with or without a night light. These devices shall comply with the applicable requirements of this Standard except as modified by the requirements in Sections 81 – 89.

81.1 added December 12, 2014

81.2 These requirements are applicable to flush-type, parallel blade construction of the ANSI/NEMA 1-15R or 5-15R configurations only. These requirements do not cover products incorporating a flush device cover plate with connection means other than plug blades.

81.2 added December 12, 2014

81.3 These requirements are applicable only to non-metallic flush device cover plates that are intended for indoor use only.

81.3 added December 12, 2014

82 Construction

82.1 In addition to the construction, performance, and marking requirements contained in this Standard, a flush device cover plate with integral power supply with one or more Class 2 output low-voltage connectors with or without a night light shall comply with the applicable requirements of the Standard for Cover Plates for Flush-Mounted Wiring Devices, UL 514D.

82.1 added December 12, 2014

82.2 The flush device cover plate profile shall not hinder the complete seating of an attachment plug of the type intended for use with the receptacle.

82.2 added December 12, 2014

82.3 A flush device cover plate with integral power supply with one or more Class 2 output low-voltage connectors with a night light shall also comply with the applicable requirements of the Standard for Direct Plug-In Nightlights, UL 1786.

82.3 added December 12, 2014

82.4 The Class 2 low-voltage output connectors of a flush device cover plate with integral power supply with one or more Class 2 output low-voltage connectors with or without a night light shall be insulated and extend beyond the plane of the receptacle mounting yoke and be accessible when the cover plate is installed as intended.

82.4 added December 12, 2014

**UL COPYRIGHTED MATERIAL –
NOT AUTHORIZED FOR FURTHER REPRODUCTION OR
DISTRIBUTION WITHOUT PERMISSION FROM UL**

82.5 The Class 2 low-voltage power supply shall be configured for supply from a single branch circuit receptacle.

82.5 added December 12, 2014

82.6 A flush device cover plate with integral power supply with one or more Class 2 output low-voltage connectors with or without a night light intended for installation requiring the removal of a receptacle cover plate shall comply with the following:

- a) The device shall be able to be fully inserted in the outlets; and
- b) The device shall be able to be fully seated against the wall such that the outlet box opening in the wall is completely covered.

82.6 added December 12, 2014

83 Polymeric Enclosures

83.1 In addition to the insulating material requirements of the Standard for Cover Plates for Flush-Mounted Wiring Devices, UL 514D, a polymeric material used to enclose the power unit circuitry shall have a flame rating not less than 5V, in accordance with the Standard for Tests for Flammability of Plastic Materials for Parts in Devices and Appliances, UL 94, or comply with the 127 mm Flame Test specified in the Standard for Polymeric Material – Use in Electrical Equipment Evaluations, UL 746C.

83.1 added December 12, 2014

84 Spacings

84.1 A flush device cover plate with integral power supply with one or more Class 2 output low-voltage connectors shall maintain a minimum of a 1/4 inch (6.35 mm) separation of branch circuit wiring and Class 2 connections after installation. Compliance shall be determined by measurement and if required, the Assembly Test in Section 87.

84.1 added December 12, 2014

84.2 Class 2 output low-voltage connectors shall be located as to prevent a line blade of an attachment plug from being improperly inserted into the Class 2 output low-voltage connector (i.e. USB) slot and the line contacts of a receptacle. Compliance shall be determined by inspection and if required, the Assembly Test in Section 87.

84.2 added December 12, 2014

85 Configurations

85.1 The device shall comply with the cover plate dimensions as specified in Wiring Devices – Dimensional Specifications, NEMA WD 6, intended to accommodate the intended flush-mounted wiring device.

85.1 added December 12, 2014

85.2 The blade portion of the device shall comply with the NEMA 1-15P or 5-15P blade dimensions specified in Wiring Devices – Dimensional Specifications, NEMA WD 6.

85.2 added December 12, 2014

86 Class 2 Output Power Supply Testing

86.1 For all testing to this Standard, except for the Assembly Test in Section 87, the device is to be energized from a duplex receptacle wired to a source of supply as intended. The duplex receptacle is to be mounted in a non-metallic outlet box test wall according to Figure 86.1. The outlet box is to be mounted in a vertical wall section as follows:

- a) With plywood or gypsum wallboard surfaces; and
- b) Loosely filled with fiberglass or equivalent thermal insulation.

86.1 added December 12, 2014

**Figure 86.1
Test setup**

Figure 86.1 added December 12, 2014

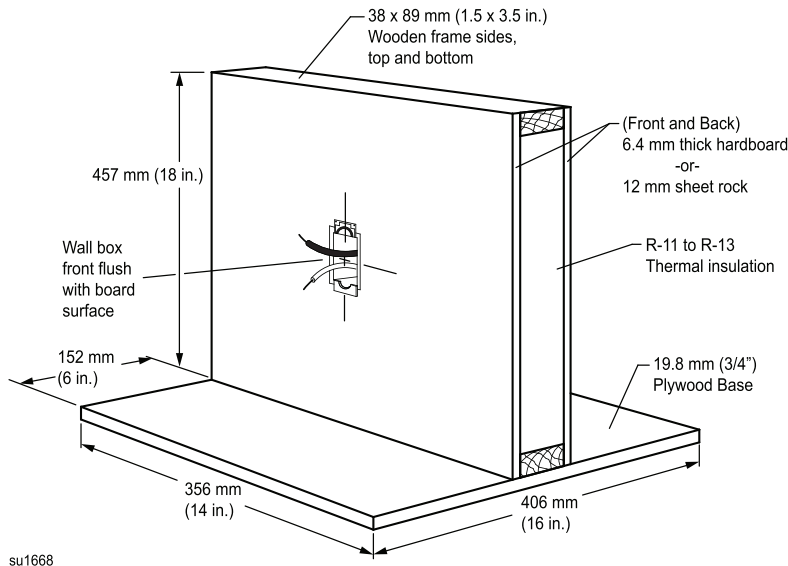

NOTE: Duplex receptacle is to be wired as intended and installed into the outlet box.

**UL COPYRIGHTED MATERIAL –
NOT AUTHORIZED FOR FURTHER REPRODUCTION OR
DISTRIBUTION WITHOUT PERMISSION FROM UL**

86.2 Under any condition of low voltage output loading, individually or collectively, tests are to be conducted to represent the worst case of:

- a) No load on the branch circuit receptacle outlet; and
- b) Full load from the branch circuit receptacle outlet.

86.2 added December 12, 2014

87 Assembly Test

87.1 A flush device cover plate with integral power supply with one or more Class 2 output low-voltage connectors with or without a night light shall comply with all of the following:

- a) Maintain a minimum of a 1/4 inch (6.35 mm) separation of branch circuit wiring and Class 2 connections;
- b) Not permit contact to be made between the probes shown in Figure 16.1, Figure 16.2, or Figure 16.4 and any live part through the Class 2 output connectors or through any opening or joint surrounding the installed device; and
- c) Not permit contact to be made between the Class 2 output connector and receptacle line contacts with a NEMA 1-15P attachment plug.

87.1 added December 12, 2014

87.2 The device is to be checked for compliance with 87.1(a). Following assembly of the test setup shown in Figure 86.1, the device is to be checked for compliance with 87.1(b). The probes of Figure 16.1, Figure 16.2, or Figure 16.4 are to be applied to any opening or joint surrounding the Class 2 output and through the Class 2 output connector slot openings with a force of 8 ounces (2.2 N) in attempt to contact live parts. A suitable indicating device (such as an ohmmeter, battery-and-buzzer combination, or similar device) is to be connected between the probe and the wiring terminal of the receptacle to determine whether contact is made. The probes are to be inserted in the Class 2 output connector slot opening successively in three directions in any orientation that may permit access to contact live parts. The probes are to be applied for approximately 5 seconds in each of the three directions. During each application, the probes are not to be moved or rotated and are to be withdrawn when moving from one direction to the next.

87.2 added December 12, 2014

87.3 The same representative assembly as described in 87.2 is to be checked for compliance with 87.1(c), using a NEMA 1-15P polarized attachment plug. One blade is to be inserted into the slot openings of the Class 2 output connector and the other blade into the slot openings of the receptacle contacts with a force of 10 pounds (45 N) in an attempt to contact live parts. A suitable indicating device (such as an ohmmeter, battery-and-buzzer combination, or similar device) is to be connected between the Class 2 output connector and the contacts of the receptacle to determine whether contact is made. The attachment plug is to be manipulated in any direction or orientation that may permit access to contact live parts. The attachment plug is to be applied for approximately 5 seconds in each direction.

87.3 added December 12, 2014

88 Installation Instructions

88.1 Installation instructions shall appear on the device, on the smallest unit container, or on a separate instruction sheet provided with each device. If the installation instructions are provided on the smallest unit container or on a separate sheet, they shall be attached to the device in such a manner that they are unable to become detached during normal conditions of handling and storage prior to initial installation or usage. The use of an individual carton, blister pack, or equivalent securing of the device to the instructions, meets the intent of the requirement. However, friction attachment shall not be employed.

88.1 added December 12, 2014

88.2 A device intended for installation with receptacle cover plate or cover plate screw removed shall be provided with detailed installation instructions to enable proper installation of the device with the cover plate removed. The inclusion of a pictorial representation is optional.

88.2 added December 12, 2014

88.3 A device intended for installation over receptacle cover plates of specific dimensions shall be provided with installation instructions that describe the maximum overall dimensions of the receptacle cover plate with which the device is intended to be used.

88.3 added December 12, 2014

88.4 A device having blade spacing not in accordance with the Standard for Current Taps and Adapters, UL 498A, Figure 9.1 – Blade and Contact Spacing, shall be provided with installation instructions that specify, by catalog number or equivalent designation, the receptacles with which the device is to be used.

88.4 added December 12, 2014

88.5 Instructions shall include information to alert the user that a single branch circuit shall supply the device. The instructions shall include a pictorial or photograph illustrating proper installation.

88.5 added December 12, 2014

89 Markings

89.1 The output Class 2 connectors shall be marked as being “Class 2” and marked with the output electrical rating. These markings shall be permanently marked and visible after installation.

89.1 added December 12, 2014

APPENDIX A

Standards for Components

Standards under which components of the products covered by this standard are evaluated include the following:

Title of Standard – UL Standard Designation

Attachment Plugs and Receptacles – UL 498

Controls for Household and Similar Use, Part 1: General Requirements, Automatic Electrical – UL 60730-1 and/or the applicable Part 2 standard from the UL 60730 series

Enclosures for Electrical Equipment, Non-Environmental Considerations – UL 50

Equipment Wiring Terminals for Use with Aluminum and/or Copper Conductors – UL 486E

Flexible Cords and Cables – UL 62

Fuseholders – Part 1: General Requirements – UL 4248-1

Gaskets and Seals – UL 157

Ground-Fault Circuit-Interrupters – UL 943

Insulating Materials – General, Systems of – UL 1446

Marking and Labeling Systems – UL 969

Organic Coatings for Steel Enclosures for Outdoor Use Electrical Equipment – UL 1332

Outlet Boxes, Metallic – UL 514A

Outlet Boxes, Nonmetallic, Flush-Device Boxes, and Covers – UL 514C

Plastic Materials for Parts in Devices and Appliances, Tests for Flammability of – UL 94

Polymeric Materials – Long Term Property Evaluations– UL 746B

Polymeric Materials – Use in Electrical Equipment Evaluations – UL 746C

Printed-Wiring Boards – UL 796

Switches, Special-Use – UL 1054 or

Switches for Appliances – Part 1: General Requirements – UL 61058-1

Temperature-Indicating and -Regulating Equipment – UL 873¹⁾

Terminal Blocks – UL 1059

Thermal-Links – Requirements and Application Guide – UL 60691

Wire Connectors – UL 486A-486B

Wires and Cables, Thermoset-Insulated – UL 44

Wires and Cables, Thermoplastic-Insulated – UL 83

¹⁾ Note: Compliance with the UL 60730-1, and/or the applicable Part 2 standard from the UL 60730 series fulfills these requirements.

No Text on This Page

***UL COPYRIGHTED MATERIAL –
NOT AUTHORIZED FOR FURTHER REPRODUCTION OR
DISTRIBUTION WITHOUT PERMISSION FROM UL***